

OPERATOR'S MANUAL

RK24
Hydrostatic

Rural King Supply
4216 Dewitt Ave.
Mattoon IL 61938

Rural King[®]



OPERATOR'S MANUAL



Rural King[®]

RK24
Hydrostatic



FORWARD

FORWARD

Thank you for purchasing our tractor. We are confident it will give you many years of reliable Service.

The introduction in this manual set out the correct manner of operating, maintaining and checking the tractor to ensure long-term durability.

Please ensure correct operation of the tractor as incorrect operation can cause substantial mechanical damage as well as cause accidents with the associated injuries.

Please note that in some cases differences can exist between this manual and your tractor due to the manufacturer's policy of constant product improvement.

In the event that you strike a problem not covered by this manual please contact your nearest RK Tractor store who will assist you in resolving your problem.



WARNING

CALIFORNIA Proposition 65 Warning





The Engine Exhaust from this product contains chemicals known to the state of California to cause cancer, birth defects or other reproductive harm.



FORWARD

WARNING SIGNS IN THIS MANUAL

The following warning signs in this manual draw additional attention to items of importance for the safe and correct operation of the tractor.

SIGN	MEANING OF THE SIGN
 DANGER	This indicates that a condition may result in harm, serious injury or death to you or other persons if the warning is not heeded. Follow the advice provided with the warning.
 WARNING	Hazard or unsafe practice that can lead to severe injury or death.
 CAUTION	Hazard or unsafe practice that can lead in injury or death.
 IMPORTANT	Instructions for the correct operation of the machine which, if followed, will ensure that it performs at it's best.

All information, illustrations and specifications in this manual are based on latest information available at the time of publication. The right is reserved to make changes at any time without notice.

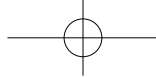

INDEX

GENERAL INFORMATION		1
SAFETY PRECAUTIONS		2
DESCRIPTION OF TRACTOR CONTROLS		3
OPERATION		4
MAINTENANCE		5
SPECIFICATION		6
TROUBLESHOOTING		7
APPENDIX		8
WARRANTY		9
INDEX		10



CONTENTS



GENERAL INFORMATION

1

- 1. TRACTOR IDENTIFICATION 1-2
- 2. ABOUT THIS MANUAL 1-3
- 3. INTRODUCTION & DESCRIPTION 1-4
- 4. OWNER ASSISTANCE 1-6
- 5. ROPS (ROLL OVER PROTECTIVE STRUCTURES).. 1-7



SAFETY PRECAUTIONS

2

- 1. SAFETY INSTRUCTIONS..... 2-2
- 2. DO'S AND DON'T'S 2-22
- 3. SAFETY SIGNS 2-24
- 4. UNIVERSAL SYMBOLS..... 2-28



DESCRIPTION OF TRACTOR CONTROLS

3

- 1. INSTRUMENT AND SWITCHES..... 3-2
- 2. OPERATION THE CONTROLS 3-8
- 3. PTO 3-13
- 4. OPERATING THE HYDRAULICS 3-15
- 5. OPERATING THE 3 POINT LINKAGE (TPL).. 3-17



OPERATION

4

- 1. STARTING THE ENGINE 4-2
- 2. STOPPING THE ENGINE 4-3
- 3. WARMING UP 4-3
- 4. NORMAL BRAKING AND PARKING 4-4
- 5. OPERATION OF THE DIFF LOCK..... 4-5
- 6. CHECK DURING DRIVING..... 4-6



LUBRICATION & MAINTENANCE

5

- 1. CHECKS AND SERVICE 5-2
- 2. MAINTENANCE AND ADJUSTMENT
SCHEDULE 5-7
- 3. FILLING DIAGRAM & CAPACITY TABLE 5-10
- 4. LUBRICANTS..... 5-11
- 5. OPENING METHOD OF EACH COVER..... 5-12
- 6. CHANGING THE OILS IN THE TRACTOR.. 5-14
- 7. CLEAN AND CHANGE FILTER..... 5-17
- 8. CHANGING THE COOLANT 5-18
- 9. GREASING THE TRACTOR 5-20
- 10. GAP ADJUSTMENT 5-20
- 11. BATTERY MAINTENANCE 5-22
- 12. FAN BELT ADJUSTMENT 5-23



CONTENTS

- 13. SERVICE THE AIR CLEANER..... 5-24
- 14. STORAGE 5-27
- 15. FUEL SAVING TIPS 5-29

SPECIFICATION 6

- 1. SPECIFICATIONS 6-2

TROUBLESHOOTING 7

- 1. TROUBLESHOOTING 7-2

APPENDIX 8

- 1. DRAWING FOR FIXING POSITION OF THE FUSE..... 8-2
- 2. WIRING DIAGRAM OF THE ELECTRIC INSTRUMENT 8-3
- 3. TRACTOR HISTORY CARD 8-4
- 4. SERVICE RECORD 8-5
- 5. DAILY OPERATION LOG 8-6
- 6. PART REPLACEMENT RECORD 8-7

WARRANTY 9

- 1. YANMAR WARRANTIES..... 9-2
- 2. EMISSION SYSTEM WARRANTY 9-5
- 3. RK WARRANTY 9-9

INDEX 10

- 1. INDEX..... 10-2

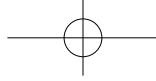

MEMO

A series of horizontal dotted lines for writing a memo.

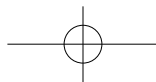
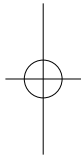
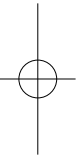



GENERAL INFORMATION

- 1. TRACTOR IDENTIFICATION 1-2
- 2. ABOUT THIS MANUAL 1-3
- 3. INTRODUCTION & DESCRIPTION..... 1-4
- 4. OWNER ASSISTANCE 1-6
- 5. ROPS (ROLL OVER PROTECTIVE STRUCTURES) ...1-7



GENERAL INFORMATION

1. TRACTOR IDENTIFICATION

The engine number is stamped on the left hand side of the engine block.

The chassis number is shown on the left hand side of the tractor as shown in the drawing.

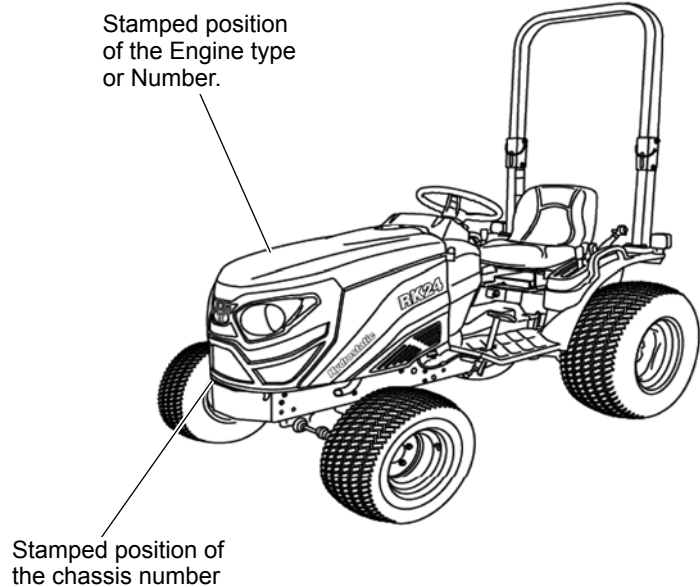

► WARRANTY OF THE PRODUCT

The manufacturer warrants this product and full details of the warranty are provided on a separate warranty schedule.

► SERVICE

Service is available from any **RK Tractor store** in the country.

► PARTS

To obtain spare parts please contact your nearest **RK Tractor store** and give him the details listed below.

- Tractor model
- Tractor serial number
- Tractor engine number
- Part number and description
- Quantity required

R24O001A



2. ABOUT THIS MANUAL

This manual has been prepared to assist you in following/adopting the correct procedure for running-in operation and maintenance of your new **RK Supply, Inc** (Here in after refer to **RK**) Tractor.

Your Tractor has been designed and built to give maximum performance, with good fuel economy and ease of operation under a wide variety of operating conditions. Prior to delivery, The tractor was carefully inspected, both at the factory and by your RK Tractor store, to ensure that it reaches you in optimum conditions .To maintain this condition and ensure trouble free performance. it is important that the routine services, as specified in this manual, are carried out at the recommended intervals.

Read this Manual carefully and keep it in a convenient place for future reference. If at any time you require advice concerning your Tractor, do not hesitate to contact your Authorized **RK Tractor store** He has trained personnel, genuine parts and necessary equipments to undertake all your service requirements.

Manufacturer's policy is one of continuous improvement, and the right to change prices, specifications or equipments at any time without notice is reserved.

All data given in this book is subject to production variations. Dimensions & weight are approximate only and the illustrations do not necessarily show Tractors in standard condition. For exact information about any particular Tractor, please consult your **RK Tractor store**.

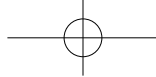

GENERAL INFORMATION

3. INTRODUCTION & DESCRIPTION

▶ TRACTOR AN INTRODUCTION

The word, 'Tractor' has been derived from 'Traction' which means pulling.

A Tractor is required to pull or haul an equipment, implement or trolley which are coupled to the Tractor body through suitable linkage. A Tractor can also be used as a prime mover as it has a power outlet source which is also called Power Take or PTO shaft.

In this book the operating, maintenance and storage instructions for all models of RK Diesel Tractors has been compiled. This material has been prepared in detail to help you in the better understanding of maintenance and efficient operation of the machine.

If you need any information not given in this manual, or require the services of a trained mechanic, please get in touch with the RK Tractor

store in your locality. RK Tractors/Distributors are kept informed of the latest methods of servicing Tractors. They stock genuine spare parts and are backed by the Company's full support.

Through this manual. The use of the terms LEFT, RIGHT, FRONT and REAR must be understood, to avoid any confusion when following the introductions. The LEFT and RIGHT means left and right sides of the Tractor when facing forward in the driver's seat, Reference to the FRONT indicates the radiator end of the Tractor, while the REAR, indicates the drawbar end (illustration T45O102B)

When spare parts are required, always specify the Tractor and engine serial number when ordering these parts. (See illustration T454101B). This will facilitate faster delivery and help ensure that the correct parts for your particular Tractor is re-

ceived. The tractor serial number is punched on a plate attached to the left hand side of the engine body (illustration T45O101B). For easy reference, we suggest you to write the number in the space provided in the owner's personal data.

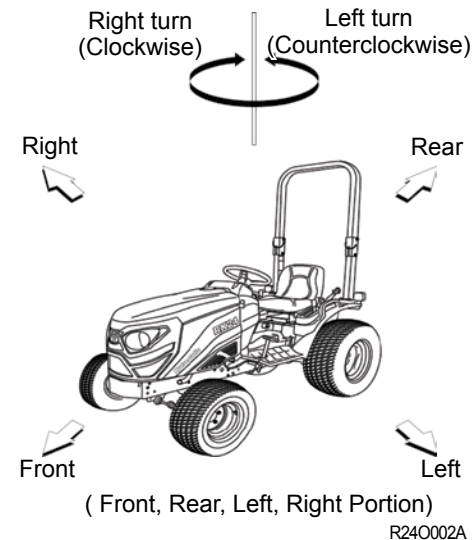

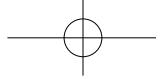

► DESCRIPTION

GENERAL CONSTRUCTION

The transmission case, Engine and Front Axle Support are bolted together to form a rigid unit.

FRONT AXLE & WHEELS

The 4WD front axle is a center-pivot, reverse Eliot type. The front wheel drive mechanism is incorporated as a part of the axle.

The front wheel drive power is taken off the rear transmission and transmitted to the differential in the front axle where the power is divided into right and left and to the respective final cases.

In the final cases, the transmitted revolution is reduced by the level gears to drive the front wheel. The 4WD mechanism with level gears provides wider steering and greater durability.

ENGINE

The tractors are fitted with fuel efficient engines with 3 cylinders manufactured by Yanmar.

TRANSMISSION WITH HST (HYDROSTATIC TRANSMISSION)

The Tractor is fitted with a 2 Range HST. Speed range by a HIGH-LOW selector lever.

The tractor has two pedals for forward/reverse control.

Tractors with Independent Power Take Off are fitted with an electro-hydraulic Clutch Assy.

The Rear PTO and Mid PTO can be operated together or separately by a lever..

BRAKES

RK tractors are provided with disc brakes operated by foot pedal. A parking brake lever is fitted for parking.

REAR AXLE & WHEELS

This is mounted on ball bearings and is enclosed in removable housing which are bolted to the transmission case. The rim & Disc fitted with Rear tires are bolted to the outer flange of Rear Axle.

HYDRAULIC SYSTEM & LINKAGES

RK Tractors are fitted with Live (i.e. system is in operation) independent, Systems.

Three point Linkages can be used for category 1(N) type of implements.

STEERING

It consists of Hydrostatic Power steering system, which has a hydraulic cylinder and tandem type hydraulic pump.

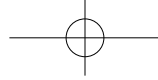

GENERAL INFORMATION

4. OWNER ASSISTANCE

ELECTRICAL SYSTEM

A 12 Volt Battery is used to activate the engine through the starter motor and the electrical system

comprising the horn, head lamp, turn signal lamp, tachometer, hour meter, brake lamp, gauge lamp, hazard lamp and general or alternator, fuse box which also from part of the electrical system.

WARNING

- When operating the tractor at High speed, Do not attempt to make sharp turns by using the brakes. This may result in overturning of the Tractor causing serious injury or DEATH.

We at **RK Supply, Inc** and your **RK Tractor store** wants you to be completely satisfied with your investment. Normally any problems with your equipment will be handled by your RK Tractor stores Service Departments, however, misunderstanding can occur. If you feel that your problem has not been handled to your satisfaction, we suggest the following.

Contact the owner or General Manager of the Dealership, explain the problem, and request assistance. When additional assistance is needed, Your RK Tractor store has direct access to your office. If you cannot obtain satisfaction by doing this, contact the **RK Supply, Inc** Office and provide them with;

- Your name, address and telephone number
- Model and tractor serial number
- RK Tractor store Name & Address
- Machine purchase date and Hours used
- Nature of problem

Before contacting **RK Supply, Inc** office, be aware that your problem will likely to be resolved in the Dealership using the RK Tractor stores facilities, equipment and personnel. So it is important that your initial contact be with the RK Tractor store.

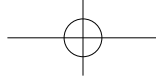

5. ROPS (ROLL OVER PROTECTIVE STRUCTURES)

1

▶ ROLL OVER PROTECTIVE STRUCTURES (ROPS)

RK Tractors are equipped with a frame for the protection of operators.

In the case of cab tractors the frame is incorporated in the cab structure.

The objective of the frame or cab structure is to protect the operator in the event of a roll over and they are designed to support the entire weight of the tractor in that event.

Each **RK** ROPS frame or cab structure is designed and has been tested to meet industry and or Government standards.

Included in these tests were all mounting bases and bolts or other fasteners.

DANGER

- For ROPS frames to be effective and protect the operator, the seat belt provided must be worn in order to keep operators within the ROPS protected area in the event of a roll over. Failure to use the seat belt can still cause serious injury or death.

On some models the ROPS frame has a fold down feature, which can be used to enter low buildings etc.

Take care when lowering the upper section of the ROPS frame and take extreme care while driving the tractor with the ROPS frame lowered.

Do not wear the seat belt with the ROPS lowered and please remember that the fold down facility is for special circumstances only and must not be lowered for general use.

▶ USE OF THE TRACTOR WITH THE ROPS LOWERED CAN CAUSE FATAL INJURIES

As the ROPS frame or cab together with the seat belt was designed to meet certain standards, they must be maintained in good order and condition.

To achieve this objective, both the structure and the seat belt should be inspected on a regular basis (every time the tractor is serviced)

In the event that the seat belt is damaged or frayed, it should be replaced and in the event that the ROPS frame or any part of the mounting structure is damaged or cracked, the faulty component must be replaced with a new unit.

Such a unit must meet all of the test criteria of the original unit.

Fitment of an inferior item or items affects the certification of the entire ROPS structure and the effectiveness of the structure in the event of an accident. Drilling or welding of the ROPS structure is forbidden.

1-7

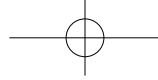

GENERAL INFORMATION

► DAMAGE OF THE ROPS

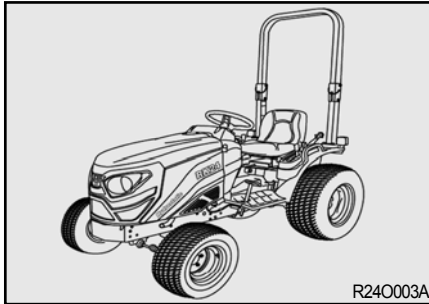

If the tractor has rolled over or the ROPS has damaged (such as striking an overhead object during transport), It must be replaced to provide the original protection. After an accident, check for damages to the 1. ROPS 2. Seat 3. Seat belt & seat mountings. Before you operate a Tractor, replace all damaged parts.

► DO NOT WELD, DRILL OR STRAIGHTEN THE ROPS

⚠ WARNING

- Never attach chains, ropes to the ROPS for pulling purposes; this will cause the Tractor to tip backwards. Always pull from the Tractor drawbar. Be careful when driving through door opening or under low overhead objects. Make sure there is sufficient overhead clearance for the ROPS to avoid fatal injuries.

⚠ WARNING

- If the ROPS is removed or replaced, make certain that the proper hardware is used to replace the ROPS and the recommended torque values are applied to the attaching bolts

⚠ WARNING

- Always wear your seat belt if the tractor is equipped with ROPS.



▶ HOW TO ADJUST THE SEAT

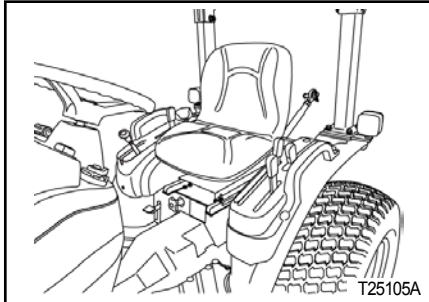

Before operating a Tractor it is important to adjust the seat to the most comfortable position & check whether it is properly locked in its position. Figure 1 identifies the seat fitted to your Tractor.

NOTE

- Do not use solvents to clean the seat. Use warm water with a little detergent added.

▶ FOR SLIDING SEAT

Slide the seat to the position you want. Release the lever.

Make sure the seat is locked in position.

⚠ DANGER

- Check whether the seat properly locked in its position before driving the tractor.

⚠ DANGER

- Always use the seat belt when the ROPS is installed. Do not use the seat belt if a foldable ROPS is down or there is no ROPS. Check the seat belt regularly and replace if frayed or damaged.



SAFETY PRECAUTIONS

- 1. SAFETY INSTRUCTIONS 2-2
- 2. DO'S AND DON'T'S 2-22
- 3. SAFETY SIGNS 2-24
- 4. UNIVERSAL SYMBOLS 2-28



SAFETY PRECAUTIONS

1. SAFETY INSTRUCTIONS

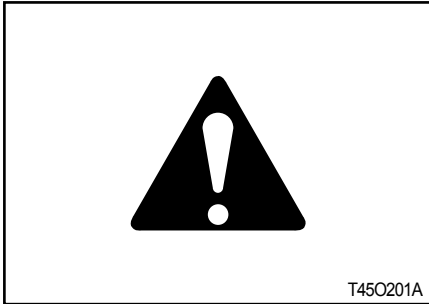

► RECOGNIZE SAFETY INFORMATION

This symbol means ATTENTION! YOUR SAFETY IS INVOLVED. The message that follows the symbol contains important information about safety. Carefully read the message.



► SIGNAL WORDS

A signal word "DANGER, WARNING OR CAUTION" is used with safety alert symbol. DANGER identifies the most serious hazards. Safety signs with signal Word "DANGER OR WARNING" are typically near specific hazards. General precautions are listed on CAUTION safety signs.

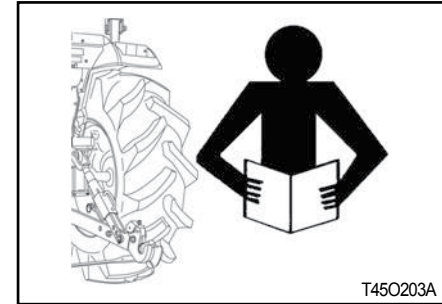

► READ SAFETY INSTRUCTION

Carefully read all safety instructions given in this manual for your safety. Tempering with any of the safety devices can cause serious injuries or death. Keep all safety signs in good condition. Replace missing or damaged safety signs.

Keep your tractor in proper condition and do not allow any unauthorized modifications to be carried out on the tractor, which may impair the function/safety and affect tractor life.



SAFETY PRECAUTIONS

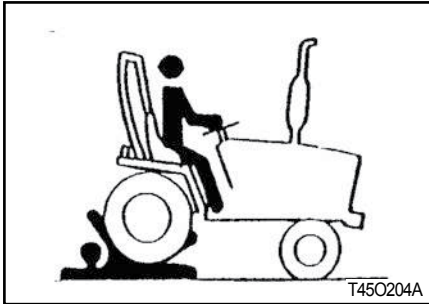

► PROTECTION CHILDREN

Keep children and others away from the tractor while operating.

BEFORE YOU REVERSE:

- Look behind tractor for children.
- Do not let children to ride on tractor or any implement.

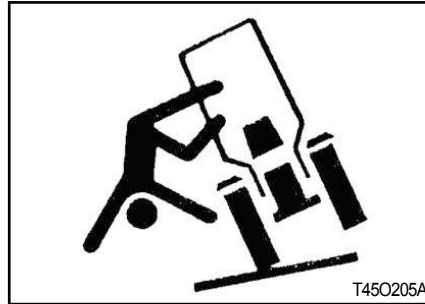

► USE OF ROPS AND SEAT BELT

The Roll Over Protective Structure (ROPS) has been certified to industry and/or government standards. Any damage or alternation to the ROPS, mounting hardware, or seat belt voids the certification and will reduce or eliminate protection for the operator in the event of a roll-over. The ROPS, mounting hardware, and seat belt should be checked after the first 100 hours of tractor and every 500 hours thereafter for any evidence of damage,

wear or cracks. In the event of damage or alteration, the ROPS must be replaced prior to further operation of the tractor.

The seat belt must be worn during machine operation when the machine is equipped with a certified ROPS.

Failure to do so will reduce or eliminate protection for the operator in the event of a roll over.



SAFETY PRECAUTIONS

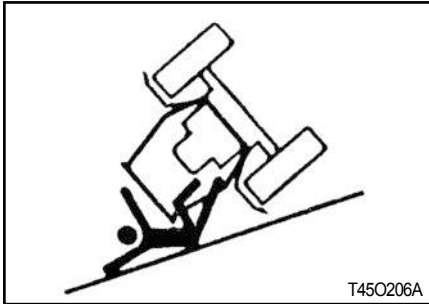

► PRECAUTION TO AVOID TIPPING

Do not drive where the tractor could slip or tip.

Stay alert for holes and rocks in the terrain, and other hidden hazards.

Slow down before you make a sharp turn.

Driving forward out of a ditch or mired condition could cause tractor to tip over backward. Back out of these situations if possible.

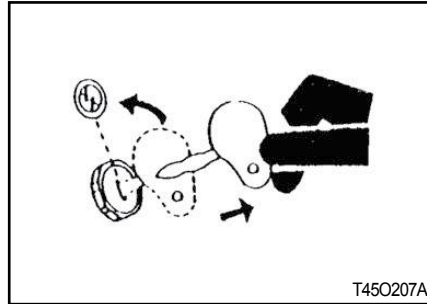

► PARK TRACTOR SAFELY

Before working on the tractor;

Lower all equipment to the ground.

Stop the engine and remove the key.

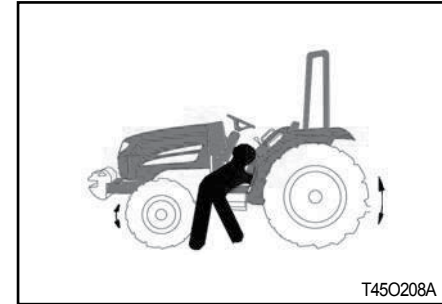

► KEEP RIDERS OFF TRACTOR

Do not allow riders on the tractor.

Riders on tractor are subject to injury such as being stuck by foreign objects and being thrown off of the tractor.

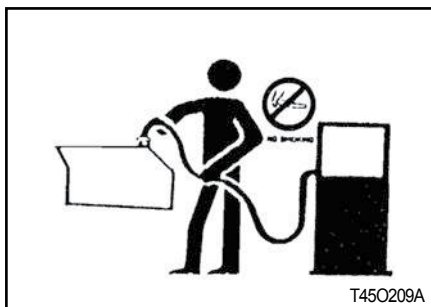

T45O209A

▶ HANDLE FUEL SAFELY AVOID FIRES

Handle fuel with care; it is highly flammable. Do not refuel the tractor while smoking or near open flame or sparks.

Always stop engine before refueling tractors.

Always keep your tractor clean of accumulated grease, and debris. Always clean up spilled fuel.



T45O210A

▶ STAY CLEAR OF ROTATING SHAFTS

Entanglement in rotating shaft can cause serious injury or death.

Keep PTO shield in place at all times.

Wear close fitting clothing. Stop the engine and be sure PTO drive is stopped before making adjustments, connections, or cleaning out PTO driven equipment.

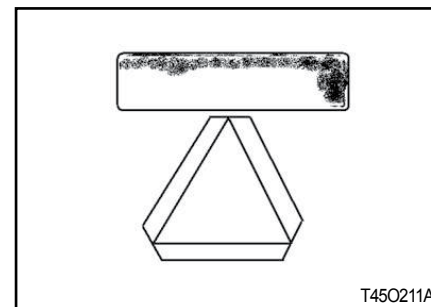

T45O211A

▶ ALWAYS USE SAFETY LIGHTS AND DEVICES

Use of hazard warning lights and turn signals are recommended when towing equipment on public roads unless prohibited by state or local regulations.

Use slow moving vehicle (SMV) sign when driving on public road during both day & night time, unless prohibited by law.



SAFETY PRECAUTIONS



► PRACTICE SAFE MAINTENANCE

Understand service procedure before doing work.

Keep the surrounding area of the tractor clean and dry.

Do not attempt to service tractor when it is in motion.

Keep body and clothing away from rotating shafts.

Always lower equipment to the ground. Stop the engine.

Remove the key. Allow tractor to cool before any work repair is caused on it.

2-6

Securely support any tractor elements that must be raised for service work.

Keep all parts in good condition and properly installed.

Replace worn or broken parts. Replace damage/missing decals.

Remove any buildup of grease or oil from the tractor.

Disconnect battery ground cable(-) before making adjustments on electrical systems or welding on tractor.



► AVOID HIGH-PRESSURE FLUIDS

Escaping fluid under pressure can penetrate the skin causing serious injury. Keep hands and body away from pinholes and nozzles, which eject fluids under high pressure. If any fluid is injected into the skin. Consult your doctor immediately.



SAFETY PRECAUTIONS

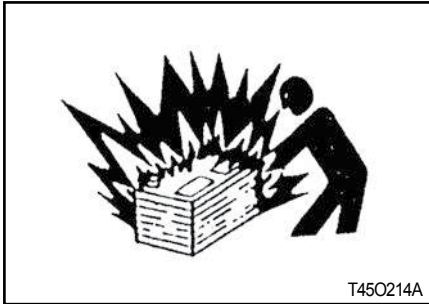

► PREVENT BATTERY EXPLOSIONS

Keep sparks, lighted matches, and open flame away from the top of battery. Battery gas can explode.

Never check battery charge by placing a metal object across the poles.

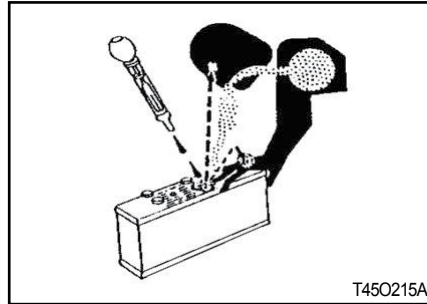

► PREVENT ACID BURNS

Sulfuric acid in battery electrolyte is poisonous. It is strong enough to burn skin, cause holes in clothing and cause blindness if found entry into eyes.

For adequate safety always;

1. Fill batteries in a well-ventilated area.
2. Wear eye protection and acid proof hand gloves.
3. Avoid breathing direct fumes when electrolyte is added.

4. Do not add water to electrolyte as it may splash off causing severe burns.

If you spill acid on yourself;

1. Flush your skin with water.
2. Flush your eyes with water for 10-15 minutes.

Get medical attention immediately.



SAFETY PRECAUTIONS

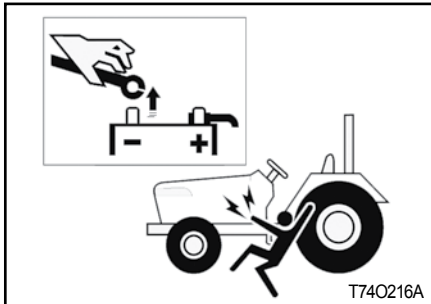

▶ BATTERY DISCONNECT

1. When working with your tractors electrical components you must first disconnect the battery cables.
2. To ensure that there are no accidents from sparks you must first disconnect the negative battery cable.

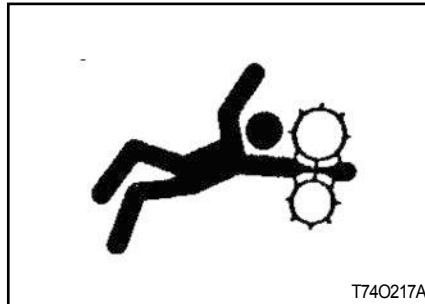

▶ SERVICE TRACTOR SAFELY

Do not wear a necktie, scarf or loose clothing when you work near moving parts. If these items were to get caught, severe injury could result.

Remove rings and other jewelry to prevent electrical shorts and entanglement in moving parts.

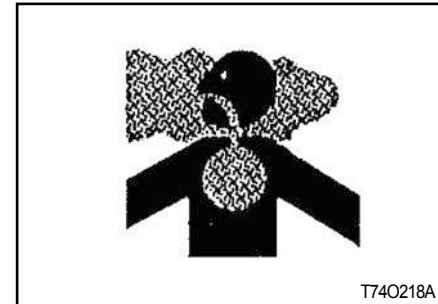

▶ WORK IN VENTILATED AREA

Do not start the tractor in an enclosed building unless the doors & windows are open for proper ventilation, as tractor fumes can cause sickness or death. If it is necessary to run an engine in an enclosed area remove the exhaust fumes by connecting exhaust pipe extension.



▶ TRACTOR RUNAWAY

1. The tractor can start even if the transmission is engaged position causing tractor to runaway and serious injury to the people standing nearby the tractor.
2. For additional safety keep the pull to stop knob (Fuel shut off control) in fully pulled out position.

Transmission in neutral position, Foot brake engaged and PTO lever in disengaged position while attending to Safety Starter Switch or any other work on tractor.

▶ SAFETY STARTER SWITCH

1. Brake operated safety switch is provided on all tractors which allow the starting system to become operational only when the Brake pedal is fully pressed.
2. Do not By-pass this safety starter switch or work on it. Only Authorized RK Tractor store are recommended to work on safety starter switch.
3. On some models Safety Starter switch is provided on transmission High-low shifter lever and in PTO shifter lever. The tractor can be started only if High-low shifter lever is in neutral position.

▲ CAUTION

- Safety Starter Switch is to be replaced after every 2,000 hours/4 years, whichever is earlier.

▶ EMERGENCY EXITS

If exit from the cab side doors is blocked (following an accident or vehicle overturn) the alternative safety exits are indicated by decals.

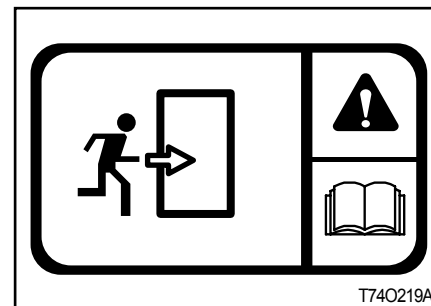

The possible safety exits are:

- Rear window hatch (All tractors)
- Front window (For versions with openable front window).



SAFETY PRECAUTIONS

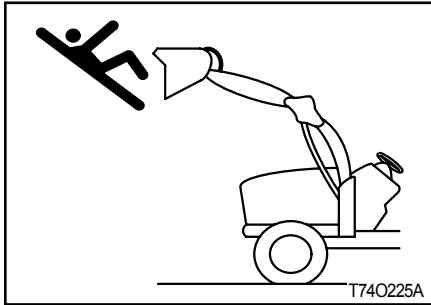

▶ SAFETY PRECAUTIONS WHEN USING THE LOADER

Never let anyone get in the loader and use the loader as a workbench. Otherwise, it may lead to a fatal injury or even death.

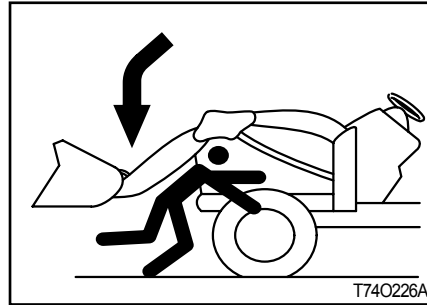

Do not stand under the lifted loader or get close to it. Also, lower the loader arm onto the ground before leaving the tractor. Otherwise, it may lead to a fatal injury or even death.

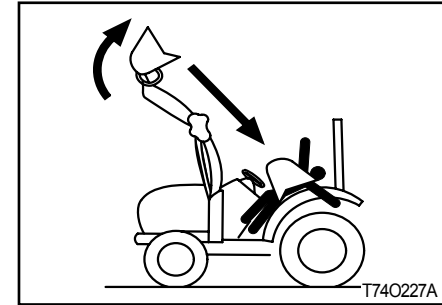

When attaching or detaching the loader, fix all parts which are connected to the bucket and boom. The bucket or boom can be accidentally dropped down, leading to an injury or even death.

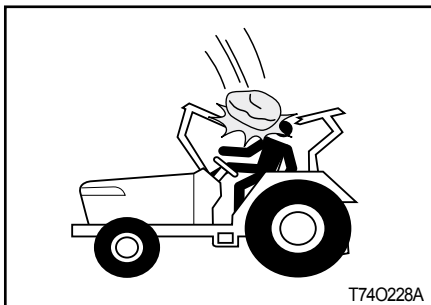

T74O228A

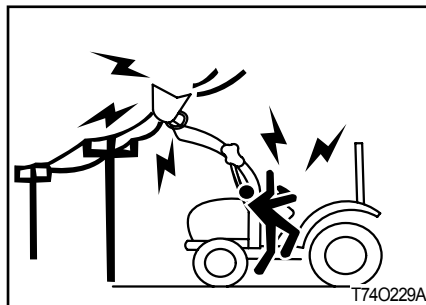

T74O229A

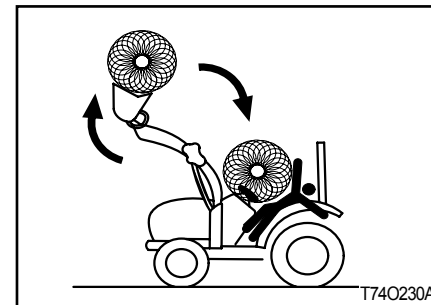

T74O230A

IMPORTANT

- ROPS (Roll Over Protective Structure), sun canopy or cabin are not a FOPS (Falling Object Protective Structure).

It never can protect the riders against falling objects.

Avoid driving the vehicle into a dangerous area such as falling rocks zone.

Do not allow loader arms or attachment to contact electrical power lines. Electrocutation will cause serious injury or death.

Never carry a big object with the loader unless a proper implement is attached. Keep a carried object low during driving. Otherwise, it may lead to an injury or even death.



SAFETY PRECAUTIONS

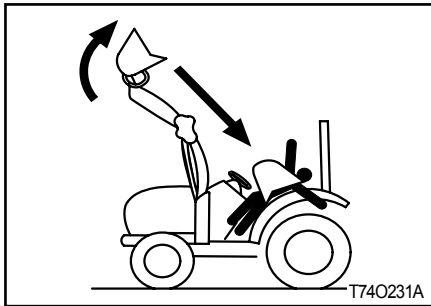

When attaching or detaching the loader, fix all parts which are connected to the bucket and boom. The bucket or boom can be accidentally dropped down, leading to an injury or even death.

► TOWING SAFELY

For the maximum towable loads, refer to the paragraph " Maximum towable loads in the Technical Data Section.

- Maintain a suitable speed taking into account the weight of the trailed load and the gradient, remembering that braking distances will be greater than with just the tractor. Trailled loads with or without brakes that are too heavy for the tractor or that towed at too high speed may cause the operator to lose control of the tractor.
- Always take into consideration the total weight of the implements and their loads.

▲ CAUTION

- When a trailer is hitched to the tractor, before you leave the driving seat remember to put all the controls in neutral, apply the handbrake, switch off the engine, engage first gear (if the tractor has a mechanical transmission) and remove the key from the starter switch. If the tractor is not parked on level ground, ALWAYS place chocks under the wheels of both the tractor and the trailer. For further information on safe working procedures, refer to the chapter "Parking the tractor" in the safe section of this manual.



- When trailers are hitched to the tractor, before you leave the operator seat remember to put all the controls in neutral, apply the handbrake, switch off the engine, engage first gear (with mechanical transmissions) and remove the ignition key. ALWAYS chock both the tractor and the trailer wheels. The best way to transport a tractor that has broken down is to transport it on a low loader. Always secure the tractor to the loader bed with chains. Before transporting the tractor on a low loader or on a railway wagon, make sure that the engine hood, doors, openable roof (if present) and windows are all closed and securely fastened. Never tow the tractor at speeds in excess of 10 kph. An operator must stay in the operator position to steer and brake the tractor.

▶ FALLING OBJECT PROTECTIVE STRUCTURE (FOPS)

The term F.O.P.S refers to structure installed on the tractor intended to reduce the risk to the operator of injury from falling objects during normal use of the vehicle.

⚠ IMPORTANT

- This tractor is equipped with a FOPS.
- The energy level of drop test is 1365J.

▶ OPERATOR PROTECTIVE STRUCTURE (OPS)

The term OPS refers to a protective structure installed on a tractor in order to minimise risk of operator injury caused by objects penetrating into the operator position area.

⚠ DANGER

- This tractor is not equipped with an OPS. If work must be performed in areas subject to the risk of the penetration of objects into the operator position, consult your RK Tractor store before starting work so that the tractor can be equipped with an appropriate protective structure.



SAFETY PRECAUTIONS

► USE OF HAZARDOUS SUBSTANCES

European standard EN 15695-1 is applicable to the cabs of agricultural or forestry tractors and self-propelled sprayers.

The purpose of the standard is to limit the exposure of the operator (driver) to hazardous substances when applying plant protection products and liquid fertilisers.

In accordance with the stipulations of EN 15695-1 regarding cab classification, measurement of the internal positive pressure differential must be carried out in conformance with ISO 14269-5:

1. The engine operating at nominal speed;
2. The maximum quantity of air drawn from outside the cab (recirculation closed);
3. Fan set to maximum speed.

2 - 14

The following terms and definitions are applied:

- Hazardous substances: substances such as dust, vapours and aerosols, with the exception of fumigants which can be dispersed during the application of plant protection products and liquid fertilisers, which may have a harmful effect on the operator.
- Dust general term identifying solid air-borne particles, finely divided and sedimented
- Aerosol: suspension of solid, liquid or solid and liquid particulate in gaseous medium with a negligible fall rate (generally less than 0.25 ms⁻¹)
- Vapour: gaseous phase of a substance whose liquid or solid state is stable at 20° C and 1 bar (absolute).
This cab, even when closed, does not protect against the inhalation of hazardous substances. If the man-

ufacturer's instructions for using these substances recommend personal protective equipment, wear the equipment even in the cab.

⚠ DANGER

- Use all the personal protective equipment suitable for the tasks in hand and relative substances, in compliance with the requirements of statutory legislation in your country.

Cabs are classified as follows:

- Category 1: the cab does not provide protection against hazardous substances.
- Category 2 the cab provides protection exclusively from dust.
- Category 3: the cab provides protection from dust and aerosol.
- Category 4: the cab provides protection from dust, aerosol and chemical vapours.



The classification category, as stipulated by ISO 14269-5, of the cab installed on this range of tractors is given below:

- the engine operating at nominal speed
- the maximum quantity of air drawn from outside the cab (recirculation closed)
- with fan at maximum speed

Tab. 2 - Technical data

	RK24H
CAB / ROPS	
Hazardous substances protection category CAB	Category 1

► SAFE OPERATION OF YOUR TRACTOR

The manufacturer of your tractor has made every effort to make it as safe as is humanly possible.

Beyond this point it is the responsibility of the operator to avoid accidents and we ask that you read and implement our suggestions for your safety.

Ensure that only trained and competent operators use this tractor and ensure that they are fully conversant with the machine and aware of all its control and safety features.

Operators should not operate the tractor or associated machinery while tired or untrained.

To avoid accidents please ensure that the operator wears clothing which will not get entangled in the moving parts of the tractor or machine and protect him or her from the elements.

When spraying or using chemicals, please ensure that clothing and protective equipment is worn which prevents respiratory or skin problems.

For full details consult the manufacturer of the chemicals.

To avoid lengthy exposure to noise ensure that ear protection is worn.

If adjustment to the tractor or machinery need to be made ensure the tractor or machine are turned off beforehand.

Use of certified Roll Over Protection Structure (ROPS) is a must while operating a tractor.

Use of seat belt is a must while operating a tractor.

In summary, ensure at all times that the safety of the operator and any other worker is paramount.

Ensure no one is between the tractor and a towed vehicle (trailer or implement).



SAFETY PRECAUTIONS

► SAFETY TIPS DURING MAINTENANCE

1. At least on a daily basis check all oil levels. Water level in the radiator and electrolyte level in the battery and perform services according to the service schedule.
2. Ensure tire pressure are even and the correct pressure for the job being done is maintained.
3. Check to ensure that the all controls and preventative mechanisms of the tractor and implement work correctly and effectively.
4. Ensure that an adequate set of the correct tools is available for maintenance and minor repairs.
5. Ensure that all service work and repairs are carried out on a flat area with a concrete or similar floor.

Do not carry out service work on a tractor until it is switched off,

and the parking brake applied and wheels chocked.

Where a tractor is started in a confined area, ensure that the area is well ventilated as exhaust gases are very harmful, and can cause death.

6. Do not work under raised implements.
7. When changing wheels or tires ensure that a suitable wheel stand is placed under the axle prior to removing the wheel and the wheels are chocked.
8. Where guards or shields need to be removed to perform a service or repair, ensure that the guard or shield is correctly reinstalled before starting the tractor.
9. Never refuel near a naked flame or with an overheated engine. Ensure to turn off Engine before refueling.

10. The cooling system operates under pressure, take care when removing the radiator cap on a hot engine to prevent being scalded by steam or hot water. Do not add water in the radiator when the engine is hot. Add water to the radiator only after the engine cools down completely.

11. To prevent fires keep the tractor including the engine clean and free from flammable material and well away from fuels and other flammable material.



► MOUNTING AND DEMOUNTING IMPLEMENTS

1. Ensure that all mounting and removal of implements is done on safe flat ground. Ensure no one is between the tractor and implement and do not get under the implement to avoid accidental injuries.
2. After mounting the implement, ensure that all sway chains are correctly adjusted and, where PTO shafts are used that the shaft is fitted and secured correctly.
3. Where heavy implements are used, ensure that the combination is well balanced or use proper ballast to achieve balance.
4. Before leaving the tractor at any time, lower the implement, stop the PTO shaft where applicable, set the parking brake and switch off the engine.
5. While operating the implements with the PTO keep all bystanders away from any moving parts and do not attempt to make adjustments while the machine is running.
6. Only the driver should ride on the tractor with the ROPS frame fitted and with the seat belt properly fastened.
7. Where young children are present, particular care should be taken and the tractor should not be moved until the whereabouts of all children is known.
8. Only trained operators should operate the tractor and so taking care to ensure that other workers are not injured. In particular they should take care during dusty operations, which will reduce visibility substantially.
9. Never start the tractor unless the transmission is out of gear, the operator is in the seat and all round safety has been checked.
10. Only operate the tractor seated in the drivers seat and never turn or brake suddenly at high speed as this can cause a roll-over and serious injury or death.
11. When traveling on a public road ensure that the tractor and driver both meet all laws relating to safety and licensing. When traveling with wide implements use red flags on the extremities and observe all legal including escort requirements.
12. When operating under adverse conditions, hilly terrain or on bad ground adjust the speed of the tractor to suit the conditions, safety comes first. Never drive down hill at high speed or with the transmission in neutral. Use of the braking capacity of the engine as well as the service brakes.
Do not try to change gear going up or down a steep slope, select the correct gear before starting.
13. Take care when traveling uphill with a heavy implement to ensure that it does not overbalance and tip up the front end.

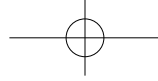

SAFETY PRECAUTIONS

14. Never remove or modify the seat belt.
15. Never remove, modify or repair the ROPS frame.

Please remember that a little bit of extra care can prevent serious injury or death and avoid damage to your tractor.

▶ THE FOLLOWING PRECAUTIONS ARE SUGGESTED TO HELP PREVENT ACCIDENTS

A careful operator is the best operator. Most accidents can be avoided by observing certain precautions. Read and take the following precautions before operating the tractor to prevent accidents.

Tractor should be operated only by those who are responsible and properly trained to do so.

<THE TRACTOR>

1. Read the operator's manual carefully before using the tractor. Lack of operating knowledge can lead to accidents.
2. Use an approved rollover bar and seat belt for safe operation. Overturning of a tractor without a rollover bar can result in death or injury.
3. Do not remove ROPS (Roll Over Protective Structure). Always use the seat belt.

4. Fiberglass canopy does not give any protection.
5. To prevent falls, keep steps and platform clear of mud and oil.
6. Do not permit anyone but the operator to ride on the tractor. There is no safety place for extra riders.
7. Replace all missing, illegible or damaged safety signs.
8. Keep safety signs clean of dirt and grease.

<SERVICING THE TRACTOR>

1. keep the tractor in good operating condition for your safety. An improperly maintained tractor can be hazardous.
2. Stop the engine before performing any service on the tractor.
3. The cooling system operates under pressure, which is controlled by the radiator cap. It is dangerous to remove the cap while the system is hot. First turn the



cap slowly to stop and allow the pressure to escape before removing the cap entirely.

4. Do not smoke while the refueling the tractor. Keep away any type of open flame.
5. The fuel in the injection system is under high pressure and can penetrate the skin. Unqualified persons should not remove or attempt to adjust a pump, injector, nozzle or any part of the fuel injection system.

Failure to follow these instructions can result in serious injury.

6. Keep open flame away from battery or cold weather starting aids to prevent fire or explosions.
7. Do not modify or alter or permit anyone else to modify or alter this tractor or any of its components or any tractor functions.

<OPERATING THE TRACTOR>

1. Before starting the tractor apply the parking brake, place the PTO (Power Take Off) switch in the "OFF" position, the hydraulic control levers in the neutral position, the remote control valve levers in the neutral position (if fitted) and the transmission in neutral.

2. Do not start the engine or controls while standing beside the tractor.

Always sit in the tractor seat when the engine is running or when operating controls.

3. Safety starter switch.

In order to prevent the accidental starting of the tractor, a safety switch has been provided. The starting system of the tractor is connected through this switch, which becomes operative only when the brake pedal is depressed. On some models shuttle shifter lever and PTO button should also be in

neutral position for completing the starting circuit. Do not bypass the safety starter switch. Consult your RK Tractor store if safety- starting switch malfunctions.

4. Avoid accidental contact with the gear shifter lever while the engine is running. Unexpected tractor movement can result from such contact.
5. Do not get off or climb the tractor while it is in motion.
6. Shut off the engine, remove the key and apply the parking brake before getting off the tractor.
7. Do not operate the tractor in an enclosed building without adequate ventilation. Exhaust fumes can cause death.
8. Do not park the tractor on a steep slope.
9. If power steering or Engine seizes to operate, stop the tractor immediately.



SAFETY PRECAUTIONS

10. Pull only from the swinging drawbar or the lower link drawbar in the down position. Use only a drawbar pin that locks in place. Pulling from the tractor rear axle carriers or any point above the rear axle may cause the tractor's front end to lift.
 11. If the front end of the tractor tends to rise when heavy implements are attached to the three-point linkage, install front end or front wheel weights. Do not operate the tractor with a light front end.
 12. Always use hydraulic position control lever when attaching equipments/implement and when transporting equipment. Be sure that the hydraulic couplers are properly mounted and will disconnect safely in case an implement accidentally detaches.
 13. Do not leave equipment/implement in the raised position.
 14. Use the flasher/ Turn signal lights and Slow Moving Vehicle (SMV) signs when driving on public roads during both day and night time, unless prohibited by law.
 15. Dim tractor lights when meeting a vehicle at night. Be sure the lights are adjusted to prevent the blinding on the eyes of coming vehicle operator.
 16. Emergency stopping instruction; If tractor fails to stop even after application of brakes. Turn off the ignition switch. (or turn off the key).
- <DRIVING THE TRACTOR>**
1. Watch where you are going especially at row ends, on roads, around trees and low hanging obstacles.
 2. To avoid upsets, drive the tractor with care and at speeds compatible with safety, especially when operating over rough ground, crossing ditches or slopes, and when turning at corners.
 3. Lock the tractor brake pedals together when transporting on roads to provide proper wheel braking.
 4. Keep the tractor in the same gear when going downhill as used when going uphill. Do not coast or free wheel down hills.
 5. Any towed vehicle and/or trailer whose total weight exceeds that of the towing tractor, must be equipped with its own brakes for safe operation.
 6. When the tractor is stuck or tires are frozen to the ground, back out to prevent upset.
 7. Always check overhead clearance, especially when transporting the tractor.

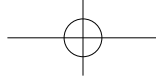

SAFETY PRECAUTIONS



2

<OPERATING THE PTO>

1. When operating PTO driven equipment, shut off the engine and wait until the PTO stops before getting off the tractor and disconnecting the equipment.
2. Do not wear loose clothing when operating the power take-off or near rotating equipment.
3. When operating stationary PTO driven equipment, always apply the tractor parking brake and block the rear wheels from front and rear side.
4. To avoid injury, always move down flip part of PTO. Do not clean, adjust or service PTO driven equipment when the tractor engine is running.
5. Make sure the PTO master shield is installed at all times and always replace the PTO shield cap when the PTO is not in use.

<DIESEL FUEL>

1. Keep the equipment clean and properly maintained.
2. Under no circumstances should gasoline, alcohol or blended fuels be added to diesel fuel.
In a closed container, such as a fuel tank, such blends are more explosive than pure gasoline. **DO NOT USE THESE BLENDS**
3. Never remove the fuel cap or refuel the tractor with the engine running.
4. Do not smoke while refueling or when standing near fuel.
5. Maintain control of the fuel filler pipe when filling the tank.
6. Do not fill the fuel tank to capacity. Allow room for expansion.
7. Wipe up spilled fuel immediately.
8. Always tighten the fuel cap securely.

9. If the original fuel tank cap is lost, replace it with genuine cap. A none approved cap may not be safe.
10. Do not drive equipment near open fire.
11. Never use fuel for cleaning purpose.
12. Arrange fuel purchases so that winter grade fuel are not held over and used in the spring.

※N.B: It is suggested that after repairs if any of the Safety Decal/sign is peeled/defaced, the same may be replaced immediately in interest of your safety.



SAFETY PRECAUTIONS

2. DO'S AND DON'T'S

▶ DO'S-FOR BETTER PERFORMANCE



- DO** - Ensure that safety shields are in place and in good condition.
- DO** - Read all operating instructions before commencing to operate tractor.
- DO** - Carry out all maintenance tasks without fail.
- DO** - Keep the air cleaner clean.
- DO** - Ensure that the correct grade of lubricating oils is used and that they are replenished and changed at the recommended intervals.

- DO** - Fit new sealing rings when the filter elements are changed.
- DO** - Watch the oil pressure gauge or warning light and investigate any abnormality immediately.
- DO** - Keep the radiator filled with clean water and in cold weather use anti-freeze mixture. Drain the system only in an emergency and fill before starting the engine.
- DO** - Ensure that the transmission is in neutral before starting the engine.
- DO** - Keep all fuel in clean storage and use a filter when filling the tank.
- DO** - Attend to minor adjustments and repairs as soon as necessity is apparent.

- DO** - Allow the engine to cool before removing the radiator filler cap and adding water, remove the radiator cap slowly.
- DO** - Shift into low gear when driving down steep hills.
- DO** - Latch the brake pedals together when driving on a highway.
- DO** - Keep draft control lever fully down when not in use.

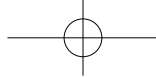

▶ **DON'TS-FOR SAFE OPERATION**

- DON'T** - Run the engine with the air cleaner disconnected.
- DON'T** - Start the tractor in an enclosed building unless the doors and windows are open for proper ventilation.
- DON'T** - Operate the tractor or engine while lubricating or cleaning.
- DON'T** - Allow the tractor to run out of diesel fuel otherwise it will be necessary to vent the system.
- DON'T** - Temper the fuel injection pump, If seal is broken the warranty becomes void.
- DON'T** - Allow the engine to run idle for a long period.
- DON'T** - Run the engine if it is not firing on all cylinders.
- DON'T** - Use the independent brakes for making turns on the highway or at high speeds.
- DON'T** - Refuel the tractor with the engine running.
- DON'T** - Mount or dismount from the right side of the tractor.
- DON'T** - Temper the hydraulic control levers' upper limit stops.
- DON'T** - Use draft control lever for lifting of implements.
- DON'T** - Start the engine with the PTO engaged.
- DON'T** - Use the governor Control Lever (Hand throttle) while driving on roads.



SAFETY PRECAUTIONS

3. SAFETY SIGNS

▶ GENERAL SAFETY INFORMATION

Replace all missing, damaged or illegible sign.

⚠ IMPORTANT

- This “General safety Information” should be kept with the machine at all times as reference data.

⚠ CAUTION

- This symbol means ATTENTION! YOUR SAFETY IS INVOLVED.

The message that follows the symbol contains important information about safety. Follow recommended precautions and safe operating practice.

▶ DECALS ON THE DASH COVER

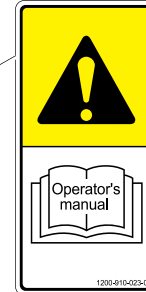
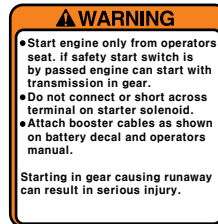



▶ DECALS ON THE CHASSIS

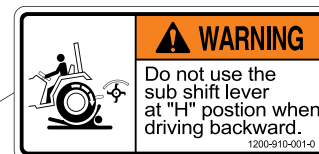
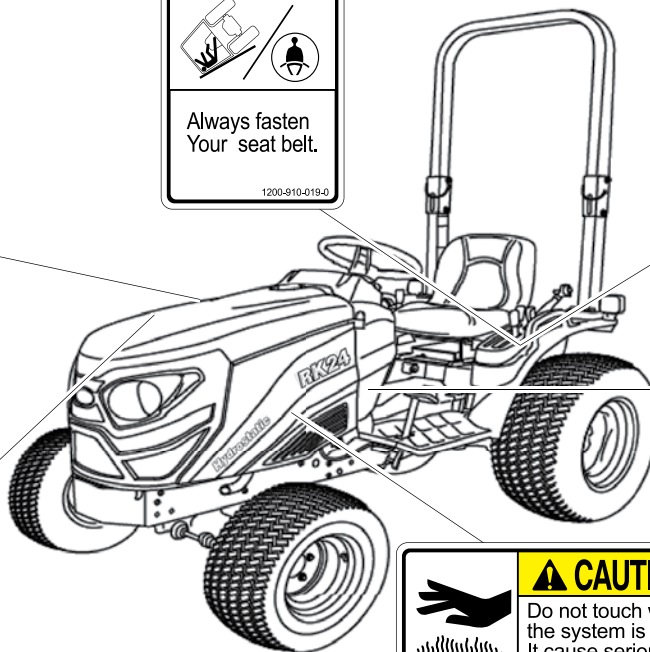
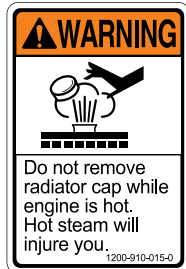

R240201A

2- 25



SAFETY PRECAUTIONS

▶ DECALS ON THE CHASSIS

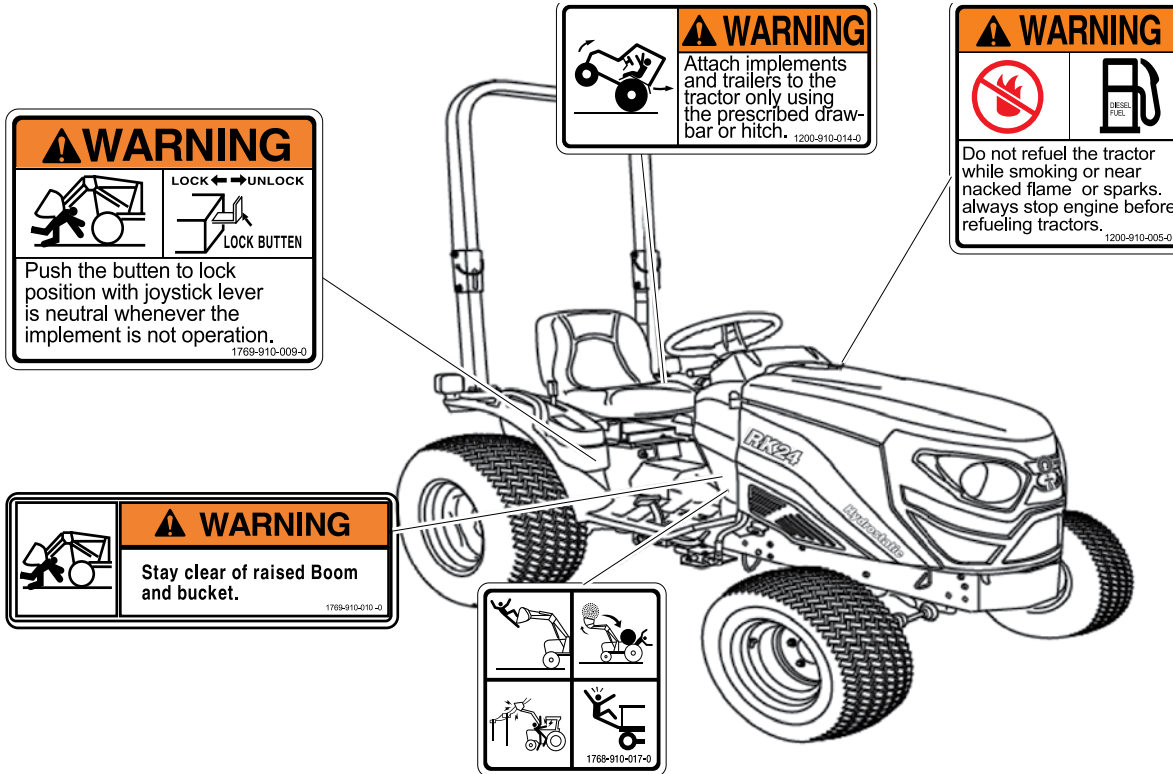

R24O20A



▶ DECALS ON THE SEAT

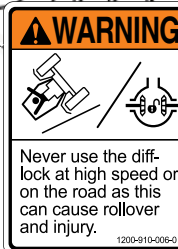
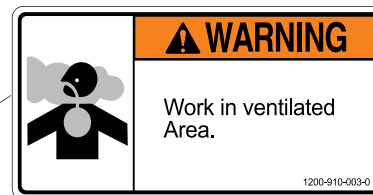
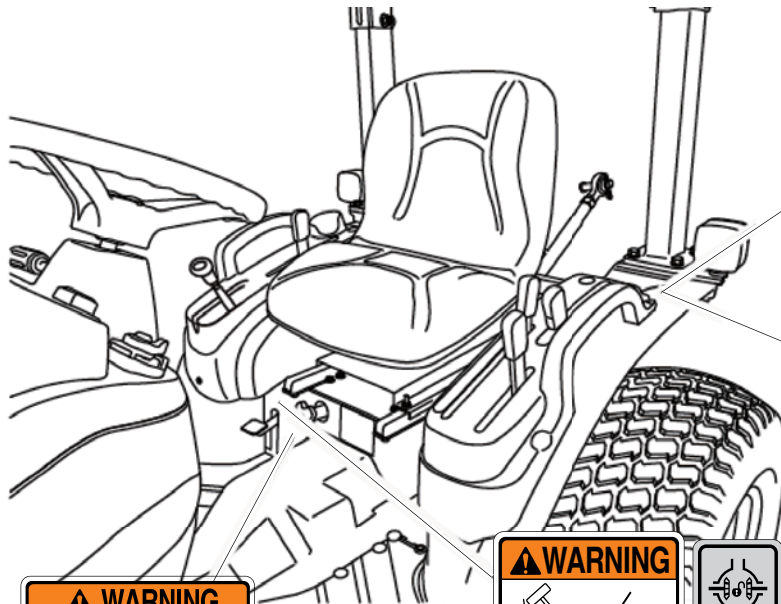

R240203A

2-27



SAFETY PRECAUTIONS

4. UNIVERSAL SYMBOLS

Some of the universal symbols have been shown below with an indication of their meaning.



Engine speed rev / min x 100)



Air filter



Power take off engaged



Turn signal



Hours, recorded



Battery charge



Power take off Disengaged



Transmission oil temperature



Engine coolant temperature



Pressured open slowly



Lift arm / raise



Parking brake



Fuel level



Continuous variable



Lift arm / lower



Work lamps



Engine Stop control



Warning



Corrosive substance



Differential lock



Lights



Hazard warning



"Tortoise" Slow or minimum setting



See operator's manual



Horn



Neutral



"Hare" fast or maximum setting



Engine oil pressure



Fan



Transmission oil pressure



DESCRIPTION OF TRACTOR CONTROLS

- 1. INSTRUMENT AND SWITCHES 3-2
- 2. OPERATION THE CONTROLS 3-8
- 3. PTO 3-13
- 4. OPERATING THE HYDRAULICS..... 3-15
- 5. OPERATING THE 3 POINT LINKAGE (TPL)..... 3-17



DESCRIPTION OF TRACTOR CONTROLS

1. INSTRUMENT AND SWITCHES

The following pages in this section detail the location and function of various instruments, switches and controls on your tractor. Even if you operate other tractors, you should read through this section of the manual and ensure that you are thoroughly familiar with the location and function of all the features of your new tractor.

Do not start the engine or attempt to drive or operate the tractor until you are fully accustomed to all the controls. It is too late to learn once the tractor is moving. If in doubt about any aspect of the operation of the tractor consult your **RK Tractor store**.

Particular attention should be paid to the recommendations for running-in to ensure that your tractor will give long life and dependable service for which it was intended.

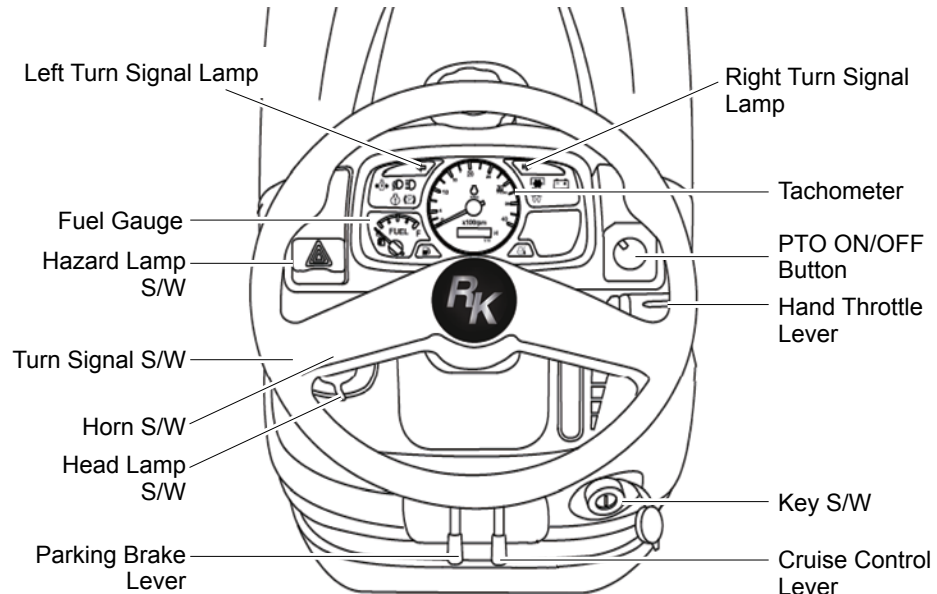

R240301A



DESCRIPTION OF TRACTOR CONTROLS

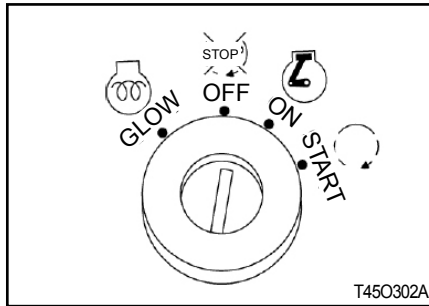

▶ MAIN SWITCH (KEY SWITCH)

- OFF - The key can be inserted or removed.
- ON - The electric circuit is on & preheat function
- GLOW - Glow plugs preheat the combustion chamber.
- START - The starter motor is engaged. When the key is released it will return to the ON position.

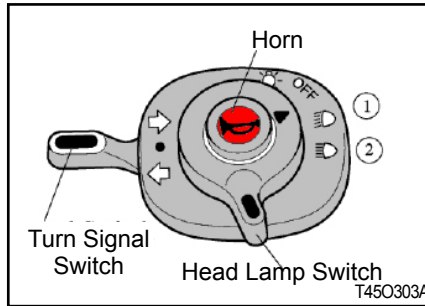

▶ HEAD LAMP, TURN SIGNAL SWITCH AND HORN

<HEAD LAMP SWITCH>

High and low beam are operated On the main switch

- Position 1. Low beam
- Position 2. High beam

<TURN SIGNAL SWITCH>

Pull the turn signal lever down to signal a left turn.

Push the turn signal lever up to signal a right turn.

<HORN>

Push the Red button.

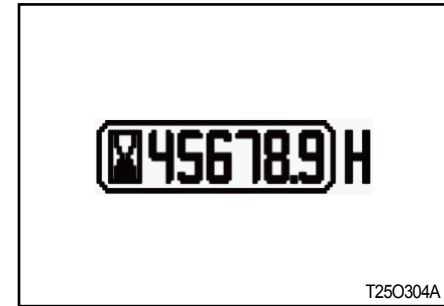

▶ HOUR METER

The hour meter consists of five digits where the last digit indicates 1/10th of an hour

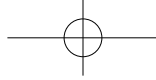

DESCRIPTION OF TRACTOR CONTROLS

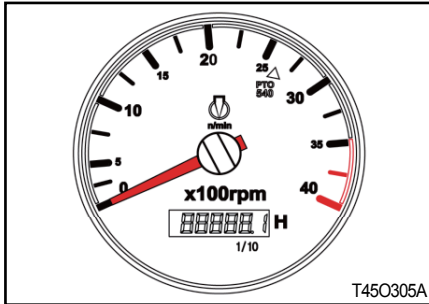

► TACHOMETER

This meter shows the revolutions of the engine and the PTO shafts as well as the travel speed in top gear.

► WATER TEMPERATURE WARNING LAMP

This comes on when the coolant temperature is over 110 degrees.

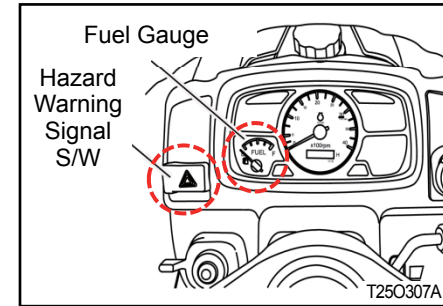

► FUEL GAUGE

Shows the amount of fuel in the tank when the ignition switch is "ON".

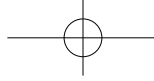

DESCRIPTION OF TRACTOR CONTROLS



► HAZARD WARNING SIGNAL SWITCH

Push the hazard warning signal once to operate the hazard warning light. (Left and right turn indicators flash)

Push the hazard warning light switch again to switch off the hazard warning lights.

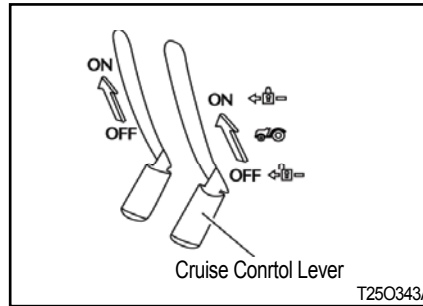

<Disengaging Cruise Control>

To disengage the cruise control you can either depress forward speed control pedal or the master brake pedal.

3

► CRUISE CONTROL LEVER

<Engaging Cruise Control>

Do not engage cruise control when reversing. Engage the cruise control as follows:

- Depress the forward speed control pedal until the required speed is achieved.
- Push up the cruise control lever to engage cruise control.
- Release the forward speed control pedal.

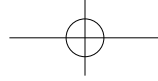

DESCRIPTION OF TRACTOR CONTROLS

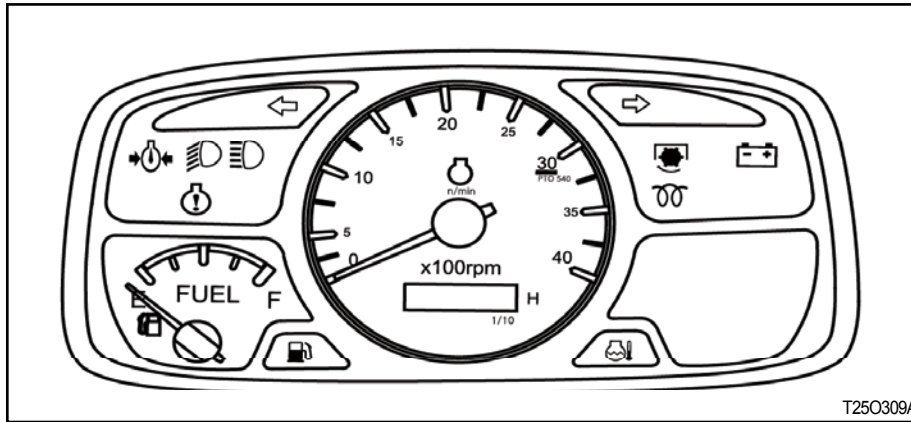

▶ PANEL INSTRUMENT LAMP



<Charge lamp>

This light will go off as soon as the engine starts to run to indicate that the alternator is changing. (Please note, as broken fan belt can cause the light to come on, please stop the engine as overheating can occur if not rectified immediately)



<Engine oil pressure lamp>

Will go out as soon as the engine starts if the oil pressure is correct. If it comes on while the engine is running, stop the engine and get expert advice.



<PTO monitor Lamp>

Shows the revolution of PTO. Refer to monitor lamp on Page 3-6.



<Fuel level indicator lamp>

If it comes on while the engine is running, Fill the tank with fuel.



High beam lamp is operated on the combination switch.



Low beam lamp is operated on the combination switch.



Glow signal Lamp indicates preheating.

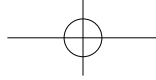

DESCRIPTION OF TRACTOR CONTROLS



<PTO monitor lamp>

The PTO monitor lamp on the dash panel indicates the state.

1. If the monitor glows:
The PTO is rotating.
2. If the monitor is off: The
PTO is off.

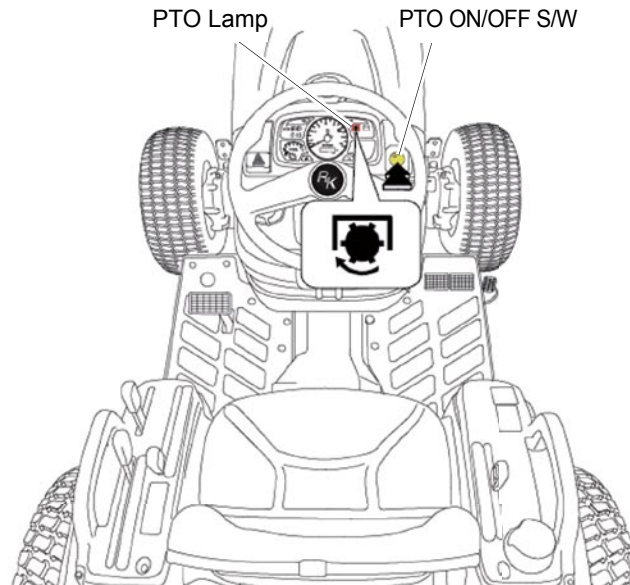

3

R24O302A

▶ PTO ON/OFF SWITCH

PTO ON/OFF switch is situated on the right hand side on the instrument panel and can be identified easily with its built in yellow colored indicator.

When the switch is pushed down to start the PTO indicator glows to indicate that the switch and the PTO are in ON position.

If the switch is pushed down and turn counter clock wise the indicator goes off signaling that the PTO is OFF.

3-7

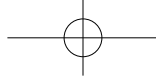

DESCRIPTION OF TRACTOR CONTROLS

2. OPERATION THE CONTROLS

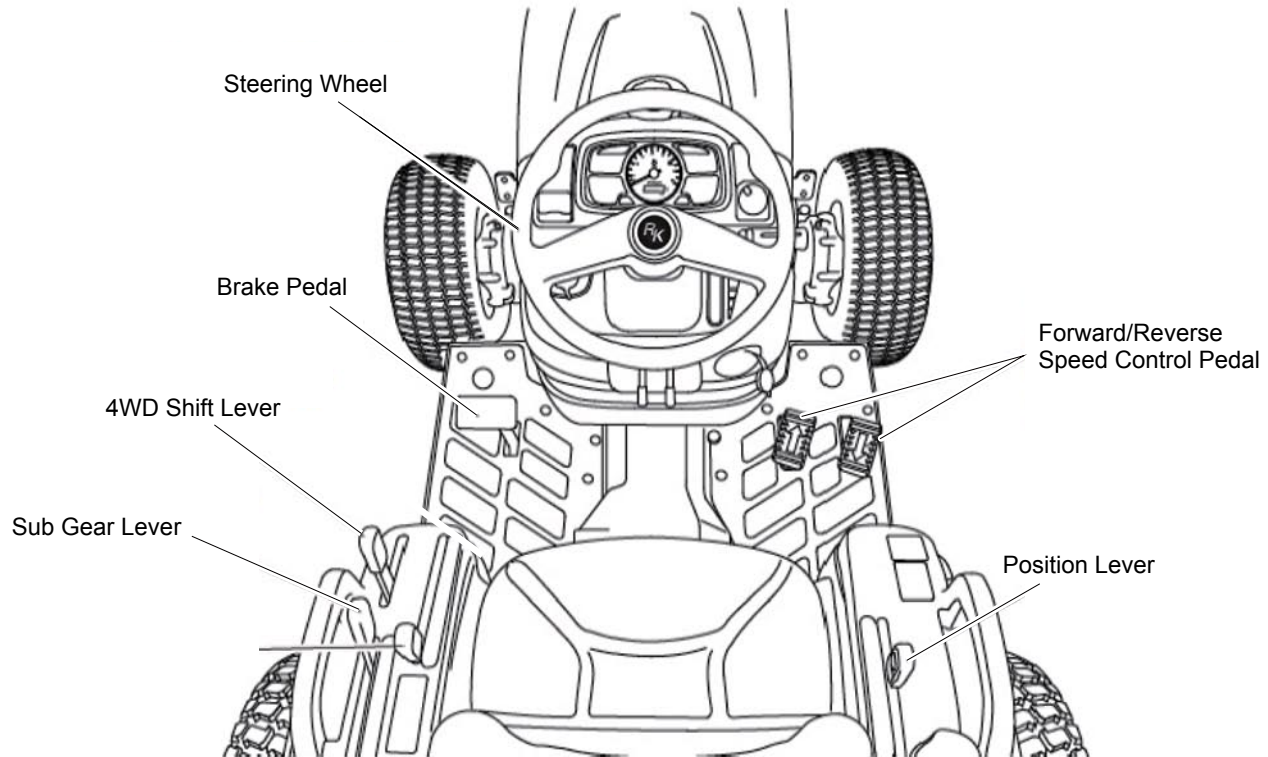

R24Q303A



DESCRIPTION OF TRACTOR CONTROLS

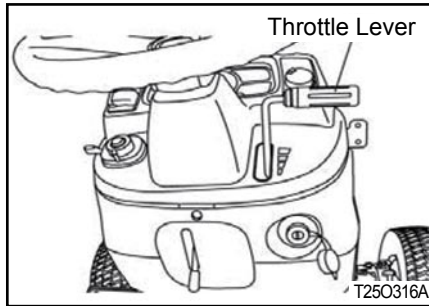

▶ THROTTLE LEVER (HAND THROTTLE)

The hand operated throttle lever is located on the RHS of the dash cover.

To increase the engine speed, pull the lever downward.

To decrease the engine speed, push the lever upward.

The Lever can be left in any position between idle and maximum as required.

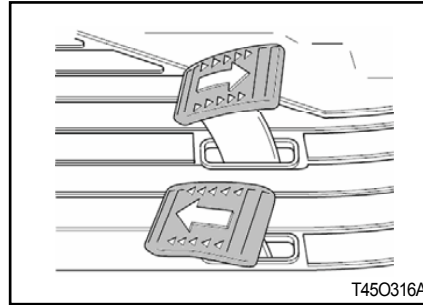

▶ SPEED CONTROL PEDAL

The Speed Control Pedal is located in the RHS of the Operator floor.

Depress the forward speed control pedal to move forward.

Depress the reverse speed control pedal to move backward.

The speed control pedal will return to neutral position and the tractor will stop when the speed control pedal is released.

IMPORTANT

- Do not change from forward to backward or backward to forward suddenly in high range.
- Sudden change may result in damage to mechanism and place the operator at risk of injury.



DESCRIPTION OF TRACTOR CONTROLS

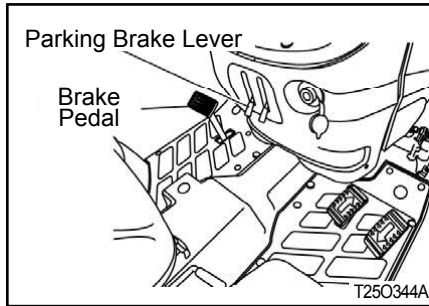

► BRAKE PEDAL

The brake pedal is located on the LHS of the operator.

It is used for two functions.

- To stop the tractor.
- To release cruise control.

► PARKING BRAKE LEVER

Push the brake pedal down while pulling the parking brake up to engage.

Press the parking brake pedal and push the brake pedal to release.

⚠ CAUTION

- Perform tight turns only at a slow safe speeds.
- Doing so at a high speed can cause rollovers and very serious injury or death.

⚠ IMPORTANT

- Traveling with the parking brake on will damage the brakes.

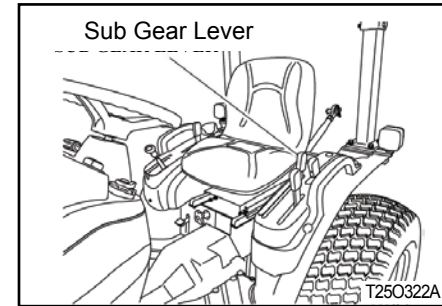

► SUB GEAR LEVER (RANGE SHIFT LEVER)

The Sub Gear Lever is located on the LHS of the operator.

Operate the sub gear lever to select the appropriate speed for different applications.

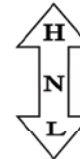



DESCRIPTION OF TRACTOR CONTROLS

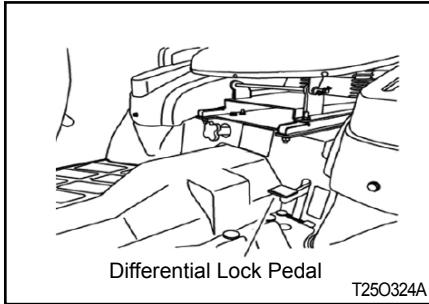

► DIFF-LOCK PEDAL

The Differential Lock Pedal is located below the LHS of the Seat.

In case of wheel slippage use the diff-lock by pushing down on the diff lock pedal.

To release it, remove the foot from the pedal

⚠ DANGER

- Tractor will be difficult to turn if the Diff-lock is engaged, ensure the lock is disengaged before turning the steering wheel.

⚠ IMPORTANT

- Do not use high engine RPM when engaging Diff lock. If the diff lock does not release after removing the foot from the diff lock pedal, alternatively brake with the left and right brake until it gets released.

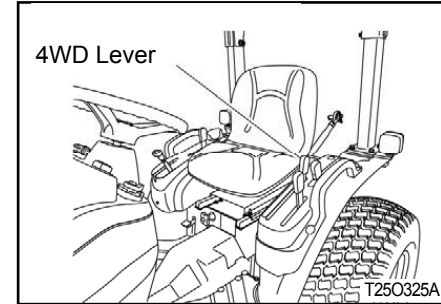

► FRONT WHEEL DRIVE LEVER

Front wheel drive lever is located below the LHS of the Operator.

In the ON position the front wheels are engaged and in the OFF position they are disengaged.

Engage & disengage the front wheel drive with the front wheels in the straight position and at low speed.

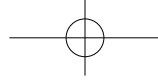

DESCRIPTION OF TRACTOR CONTROLS

IMPORTANT

- Do not use front wheel drive at high speed or on the road as premature wear of components will result.

Use of front wheel drive improves traction performance.

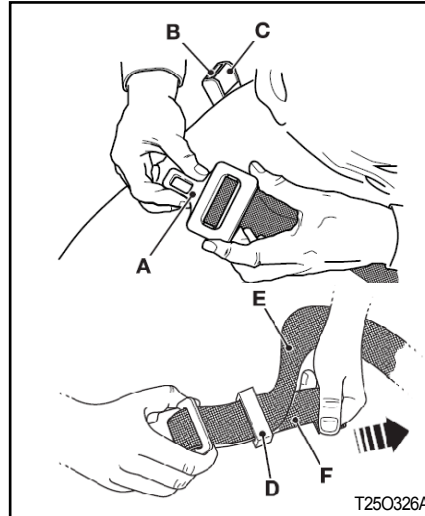

► DRIVER'S SEAT

To adjust the seat backwards and forwards, lift the lever at the front of the seat and set it to the desired position

<Operating the Safety Switch>

If you do not sit on your seat when you operate the Tractor, the engine will turn off.

<Seat Belt>

• Release the Seat Belt

Press button C and Pull the Male Fitting A from the Buckle B.

• Adjusting the Seat Belt

Make Sure the belt is across your hip and not over your stomach.

To adjust the male fitting A:

- Pull toggle D down the strap by the required distance.

- To make the strap longer, pull end E as far as it will go.
- To make the strap shorter, pull end F as far as it will go.



DESCRIPTION OF TRACTOR CONTROLS



3. PTO

Both of the rear and mid PTO are provided for variable utility. They can be engaged simultaneously or separately at same time.

The engine will not start if PTO switch is ON position.

The engine will shutoff if the operator leaves the seat with parking brake released and PTO engaged.

CAUTION

- To avoid damage of transmission and implement, do not engage PTO with the engine running at high speed.

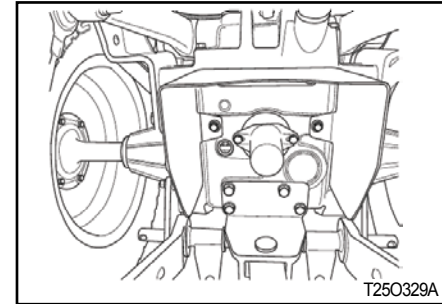
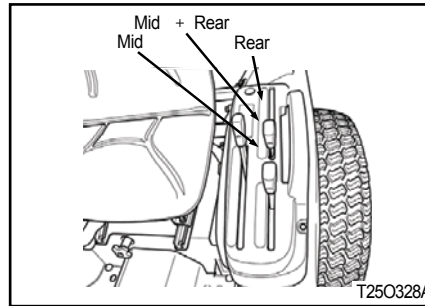

3

► REAR PTO

The tractor has one speed PTO (540 rpm). Use the PTO lever to engage. The PTO switch must be OFF before PTO is engaged.

1. Decrease engine speed to near idle.
2. Make sure that PTO switch is OFF.
3. Engage rear PTO using the PTO lever.
4. Turn on the PTO switch.
5. Increase engine speed to desired speed.

Engine RPM	Rear PTO Speed
2893	540 RPM
3000	560 RPM



DESCRIPTION OF TRACTOR CONTROLS

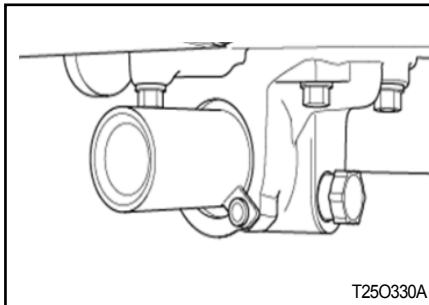
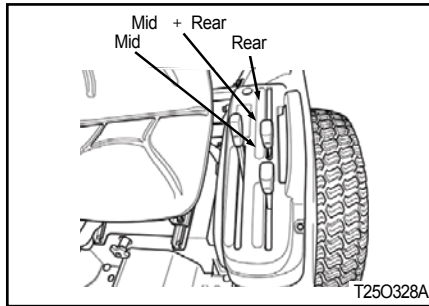

The PTO switch must be OFF before PTO is engaged.

1. Decrease engine speed to near idle.
2. Make sure that PTO switch is OFF.
3. Engage mid PTO using the PTO lever.
4. If rear PTO is needed to engage, shift the PTO lever to correct position.
5. Turn on the PTO switch.
6. Increase engine speed to desired speed.

Engine RPM	Mid PTO Speed
2875	2000 RPM
3000	2087 RPM

► MID PTO

The speed of mid PTO is 2,000rpm. Use the PTO lever to engage.

IMPORTANT

- If operator turns off PTO switch, rear PTO and mid PTO are off at once.

CAUTION

- Do not operate any implement at a high speed than is specified for it.
- When making adjustments to the implement stop the engine to avoid serious injury.
- When leaving the tractor stop the engine, and remove the key. Set the parking brake. .



DESCRIPTION OF TRACTOR CONTROLS



4. OPERATING THE HYDRAULICS

The hydraulics are powered with an engine driven hydraulic pump and controlled with a position control lever mounted beside the driver.

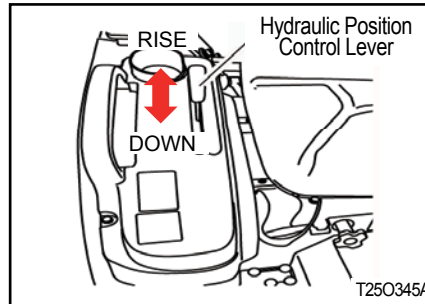

► HYDRAULIC POSITION CONTROL LEVER

The Hydraulic Position Control Lever is located on the RHS of the operator.

Implements can be raised and lowered with the hydraulic position control lever and can be stopped at any position by stopping the lever.

- To raise the implement: Pull the lever backward.
- To lower the implement: Push the lever forward.

⚠ WARNING

- After finishing the work, always lower the implement to the ground and switch off the engine, set the parking brake to avoid injuries and accidents.

3



DESCRIPTION OF TRACTOR CONTROLS

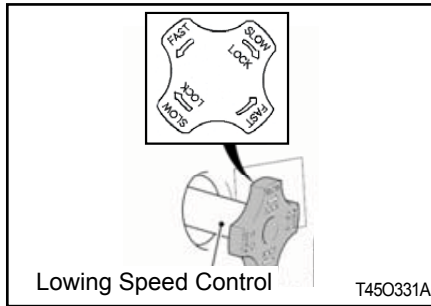

▶ LOWERING SPEED CONTROL KNOB FOR THE 3 POINT HITCH

This knob controls the downward speed of the Hydraulic's three point linkage and is located below the seat.

To slow the downward speed, turn the knob clockwise.

To increase the downward speed, turn the knob counterclock-wise.

To lock, turn the knob clockwise; Do not over tighten the knob.

3 - 16

⚠ CAUTION

Always set the knob to lock when

- Traveling on the road .
- Replacing tires or blades on an implement.
- Making adjustments to an implement. Sudden dropping of an implement due to hydraulic problems can cause serious injury or death.



5. OPERATING THE 3 POINT LINKAGE (TPL)

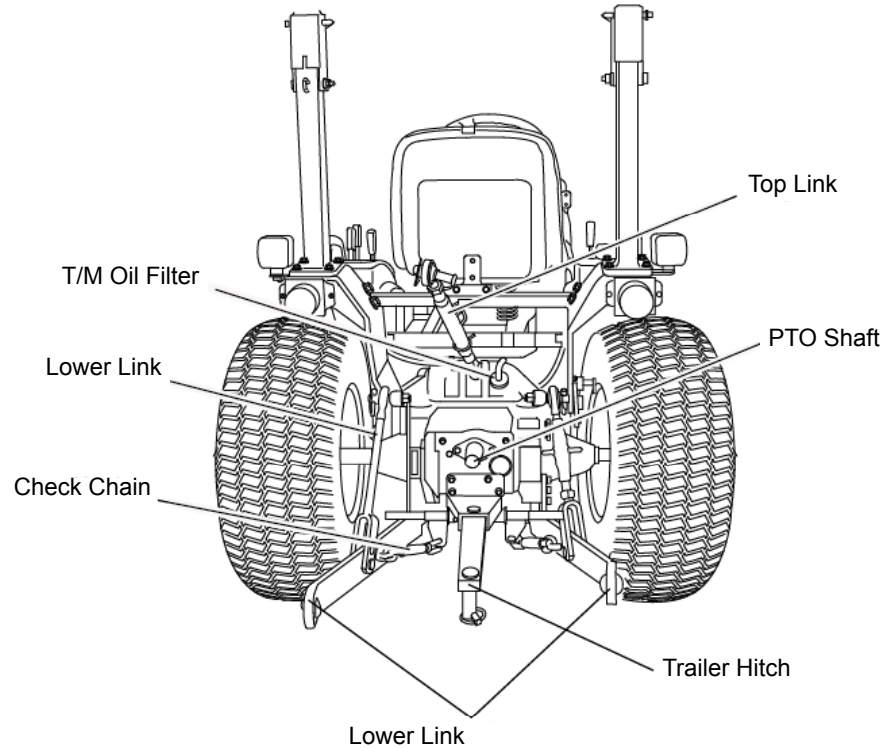

T25O337A



DESCRIPTION OF TRACTOR CONTROLS

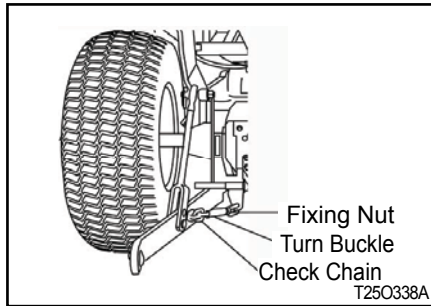

▶ ADJUSTMENT OF THE CHECK CHAIN

To adjust the check chain turn the turnbuckle to lengthen or shorten the chain and tighten the lock nut when the correct adjustment is achieved.

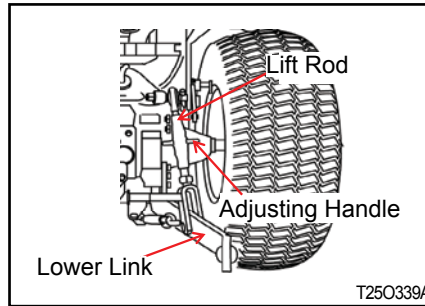

▶ ADJUSTMENT OF THE LIFT ROD

Adjust the length of the lift rod by screwing the Adjusting Handle (Turnbuckle) in or Adjust the length of the lift rod as necessary to set the implement in its working position parallel to the ground.

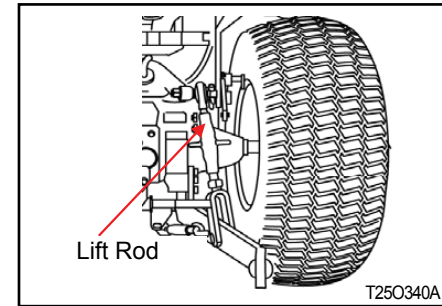

▶ ADJUSTMENT OF THE YOKE ROD ON THE LOWER LINK

For different applications change the position of the Yoke rod on the lower link holes as shown and insert the pin in the direction of the arrow.



DESCRIPTION OF TRACTOR CONTROLS



⚠ DANGER

- Only use drawbar to tow and keep the 3 point linkage in the raised position when towing with the drawbar.
- Position can create unbalance causing the tractor to roll-over & result in the death or serious injury.

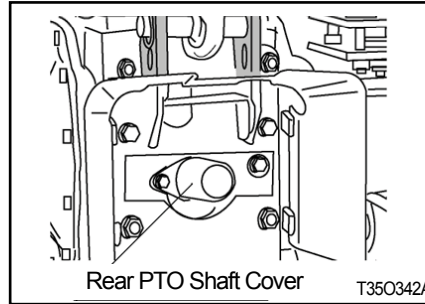

► MOUNTING IMPLEMENT

If the PTO is used, remove the safety cover off the PTO shaft.

Adjust the yoke rod on the lower links to suit the implement in use.

Attach the left lower link, then attach the right lower link using the adjusting handle on the leveling box if required.

Attach the top link.

Attach the PTO shaft to the tractor if used, making sure that it is locked in place.

Adjust the check chains to suit the implement and tighten the locknuts. To remove an implement reverses the procedure.

⚠ CAUTION

- Do not attach a PTO shaft with the engine running and ensure all safety shields are in place.

3

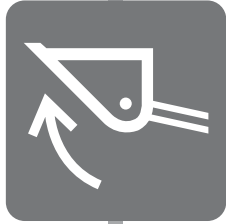

OPERATION

- 1. STARTING THE ENGINE 4-2
- 2. STOPPING THE ENGINE 4-3
- 3. WARMING UP 4-3
- 4. NORMAL BRAKING AND PARKING 4-4
- 5. OPERATION OF THE DIFF LOCK 4-5
- 6. CHECK DURING DRIVING..... 4-6

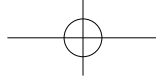

OPERATION

1. STARTING THE ENGINE

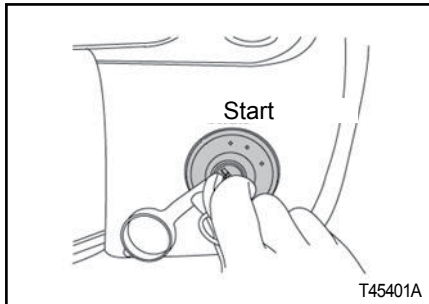

Before starting the engine carry out the pre-operational checks as set out on page 2-2.

1. Sit on the driver seat.
2. Apply the foot brake.
3. Put the hydraulic lever in the neutral position.
4. Push down the Brake to activate the safety-starting switch.
5. Put the main gear lever in neutral.
6. Insert the ignition key and turn it on.

7. Ensure that the warning lights are working.
8. Always turn the ignition key to left for a moment & release it.
The automatic heater will start working as will be indicated by a light on the instrument panel .
As the lamp goes off, turn the key to the start position to start the engine.
9. Ensure that all the warning lights are off with the engine running.

IMPORTANT

- Never turn the key to the start position while the engine is running as this can cause serious damage to the starter and engine flywheel.
- Only engage the starter for a period of not more than 10 seconds.
- If Engine does not start, rest the starter for about 20 seconds and try again for a maximum of 10 seconds. If the engine does not start after repeated attempts, refer to the fault tracing guide.
- Especially in cold weather, always allow the tractor to idle for a while to warm up & build up sufficient oil pressure to ensure normal operating temperature for longer engine life.



2. STOPPING THE ENGINE

After light work let the engine idle for a while and turn the key off.

IMPORTANT

- After long or heavy work allow the engine to idle for 5~10 minutes and turn the key off.

3. WARMING UP

When starting the engine allow it to warm up to operating temperature by allowing it to idle 5-10 minutes to ensure full lubrication and operating temperature.

Failure to do so can shorten engine life substantially.

► WARMING UP IN COLD WEATHER

Cold weather will change the viscosity of the oil, resulting in a reduced oil pumping capacity, which can cause damage to the engine if it is not warmed up correctly.

It also causes problems with the hydraulic system and the synchromesh in the transmission.

< WARMING UP TIME >

Temperature	Time for warming up
Above 50°F	5~10 min.
50°F~ 32°F	10~20 min.
32°F~14°F	20~30 min.
14°F~-4°F	30~40 min.
Below -4°F	Over 40 min.

IMPORTANT

- Ensure the handbrake (Foot brake) is on during the warming period.
- Failure to warm up correctly can result in problems.

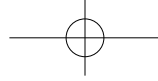

OPERATION

4. NORMAL BRAKING AND PARKING

▶ STORING ENGINE IN OPERABLE CONDITION FOR 3 MONTHS OR MORE

When the engine is not operated during storage of three months or more, internal engine parts can rust and lose oil film. As a result, the engine can seize when it is started after storage.

To prevent such a rust, the engine must be operated periodically during storage.

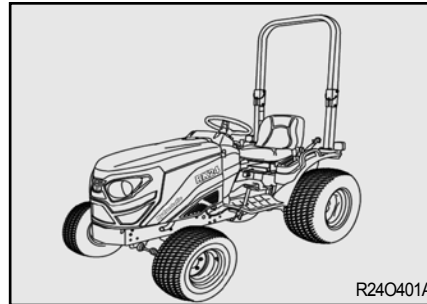

CAUTION

- Always apply the park brake when parking.
- Failure to do so can cause accidents and damage.
- As an extra precaution when parking on a slope, chock the rear wheels.

Let the engine come back to idle and at the same time push in the brake simultaneously.

When the tractor has come to a halt, lower any implement to the ground, and put the main gear in neutral.

Apply the park brake, stop the engine, and remove the key.

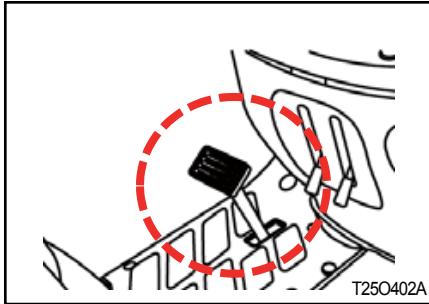

► DRIVING DOWNHILL

Use the engine's ability to brake when traveling downhill.

Never rely on the brakes only and never travel downhill with the gears in neutral.

▲ CAUTION

- When operating in hilly terrain the risk of the rollover is increased substantially, please drive with extra care.
- When towing trailers in hilly terrain ensure that they are equipped with brakes, use a lower gear to get maximum engine braking and do not change gears on a down hill run.

5. OPERATION OF THE DIFF LOCK

While the diff lock is a very useful feature, care should be taken in its use as misuse can lead to dangerous situations.

The diff lock would only be used in situations where traction is lost on one of the rear wheels.

▲ WARNING

- Use low engine revolutions when using the diff lock.
- Do not try to engage or use the diff lock on tight turns as serious damage can result.



OPERATION

6. CHECK DURING DRIVING

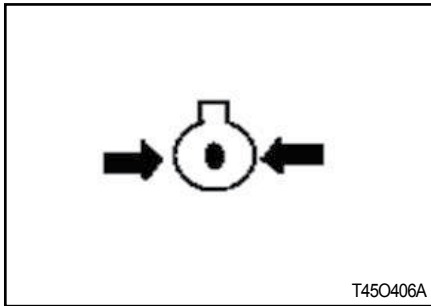

Constantly monitor the warning lights on the dash and if any comes on stop the tractor to determine the cause.

► OIL PRESSURE LIGHT

If the oil pressure light comes on check the oil level first of all.

If the oil level is OK ask a qualified RK Tractor store to check the reason for the light coming on.

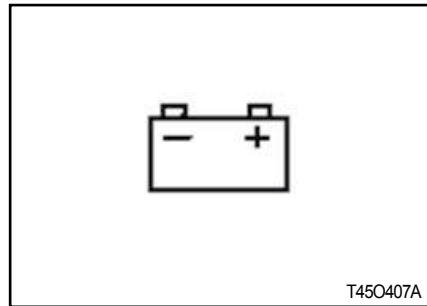

► BATTERY CHARGING

If the alternator warning light comes on check all connections and ensure that the fan belt is not broken.

If all connections and the fan belt are intact consult your RK Tractor store to determine the cause of the problem.

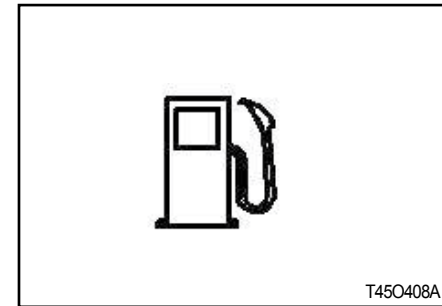

► FUEL GAUGE

To avoid excessive condensation in the fuel tank refill at the end of each day's work and ensure during the day that it does not drop to a low level where the fuel system will require bleeding to expel air in the system after refilling the tank.

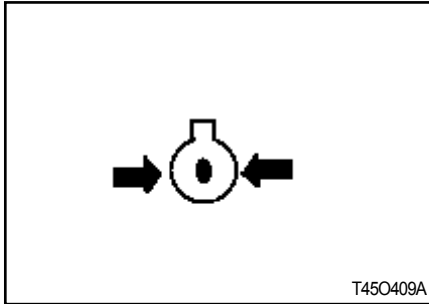

► ENGINE COOLING WATER

If the gauge indicates that the engine is running hot, stop the tractor and check the coolant in the radiator.

⚠ DANGER

- Allow the engine to cool down before opening radiator cap as serious burns may result due to hot steam & boiling water.

Also check to ensure that the fins in the radiator core are not clogged or that the tractor has a broken or stretched fan belt.

⚠ CAUTION

- When traveling on public or farm roads connect both brake pedals and allow for the weight of any mounted implement to ensure that the unit is not unbalanced.
- Also allow for the width when passing other road users.
- Where fitted use the hazard lights provided.
- Strictly follow the local traffic regulations.
- When operating near others with an implement attached take particular care to allow for the width of the implement and avoid accidents.

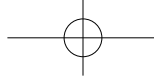

OPERATION

MEMO

Horizontal dashed lines for memo writing.

4-8

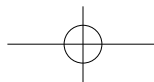

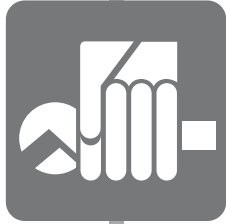

LUBRICATION & MAINTENANCE

- 1. CHECKS AND SERVICE 5-2
- 2. MAINTENANCE AND ADJUSTMENT SCHEDULE . 5-7
- 3. FILLING DIAGRAM & CAPACITY TABLE 5-10
- 4. LUBRICANTS 5-11
- 5. OPENING METHOD OF EACH COVER 5-12
- 6. CHANGING THE OILS IN THE TRACTOR 5-14
- 7. CLEAN AND CHANGE FILTER..... 5-17
- 8. CHANGING THE COOLANT 5-18
- 9. GREASING THE TRACTOR..... 5-20
- 10. GAP ADJUSTMENT 5-20
- 11. BATTERY MAINTENANCE..... 5-22
- 12. FAN BELT ADJUSTMENT 5-23
- 13. SERVICE THE AIR CLEANER 5-24
- 14. STORAGE..... 5-27
- 15. FUEL SAVING TIPS..... 5-29



LUBRICATION & MAINTENANCE

1. CHECKS AND SERVICE

► GENERAL INFORMATION

This section gives full details of the service procedures necessary to maintain your tractor at peak efficiency while the lubrication and maintenance chart provides a ready reference to these requirements.

► PRE-START CHECKS

To avoid problems it is recommended that a range of checks be carried out daily before starting the tractor.

For full details of the items and frequency please refer to the tables on page 5-6, 5-7 and 5-8.

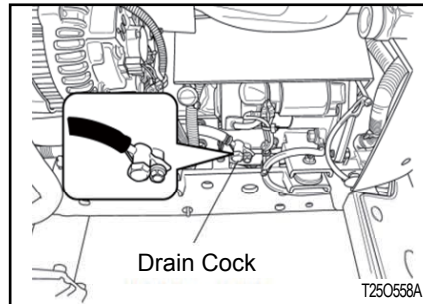
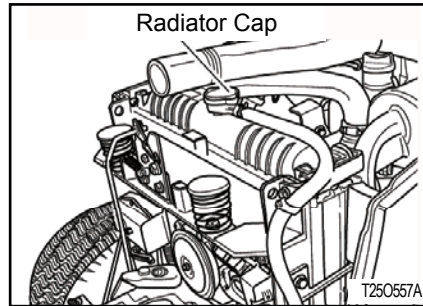

► CHECKING ENGINE COOLANT

Remove the radiator cap and ensure that the coolant is up to the filler neck and that it is clean with the correct anti-freeze or anti corrosion inhibitor in it.

If the coolant is a rusty color, drain the system completely and refill with the correct mixture of water and anti-freeze or corrosion inhibitor.

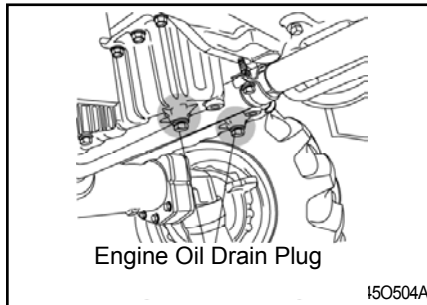
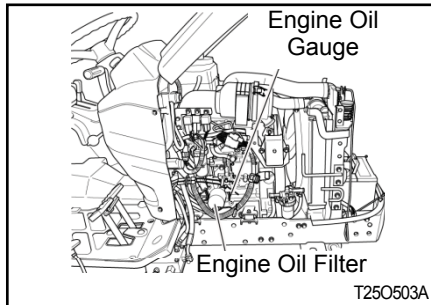
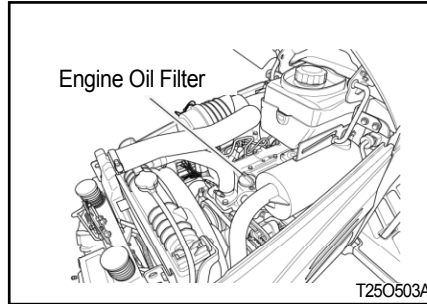
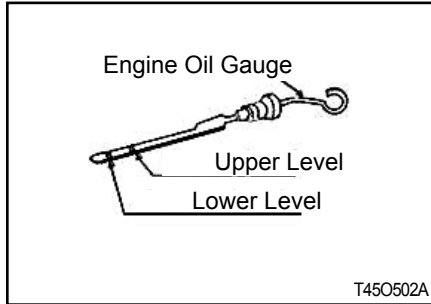

► ENGINE OIL

Pull out the stick, wipe it and dip in the oil sump.

Ensure that oil level is between the upper and lower mark near the upper mark. If too low add oil, but never after the 100hrs of service interval.

IMPORTANT

- Do not overfill the crankcase with oil.

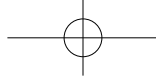

LUBRICATION & MAINTENANCE

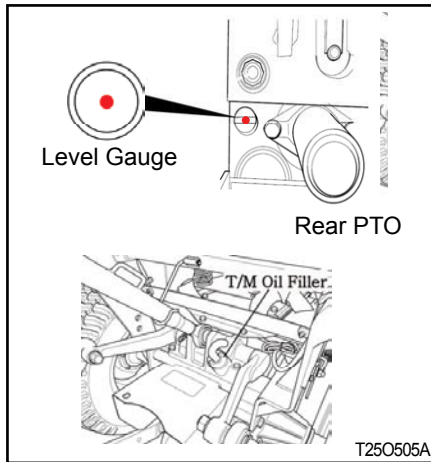

► TRANSMISSION OIL

Check the level with level gauge on rear of the transmission.

If the level is low add oil through the filler hole.

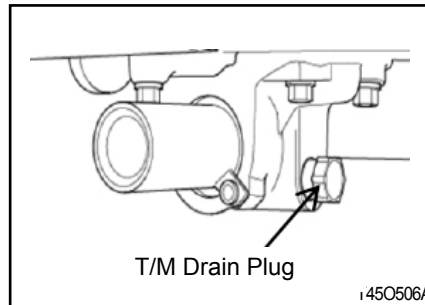

▲ CAUTION

- Always ensure that you use the correct oil for topping up or oil changes.

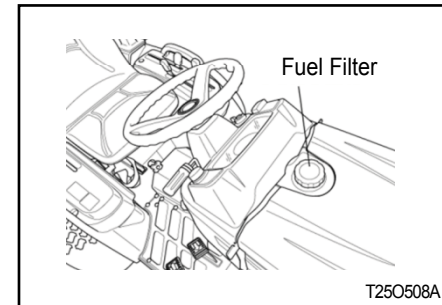

► FUEL

The Fuel Filler is located on the back side of bonnet.

Use the fuel gauge to check the fuel level and top up if too low.

It is a good practice to refill the tank immediately after use to avoid condensation.

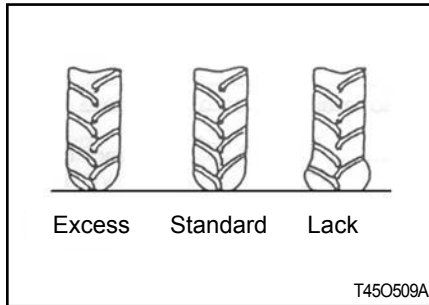

► TIRE PRESSURE

The air pressure used in the tires has a direct bearing on the life of the tire and its performance in the field.

Ensure that the tire pressures are correct and in accordance with the table on page 7-6.

To make a visual judgment see the drawing on the right.

⚠ IMPORTANT

- It is strongly recommended that tire pressures are checked with a proper gauge only & visual inspections are relied upon.

⚠ DANGER

- Excess tire pressure can cause accidents!

► STEERING

Ensure that the steering wheel does not have excessive free play.

► BRAKE

Ensure that the left and right brakes are adjusted correctly so they operate simultaneously. The correct free play on the brake is 1.18~1.57 in. (30~40 mm).

► ELECTRICAL

Check the operation of all gauge, switches, horn, lights and indicators.

► INSTALLING LOADER

1. Connect P port of loader control valve to the line on the tractor marked P. (From the PTO valve)
2. Connect the T port on the loader control valve to the line on the tractor marked T.
3. Connect the remaining line from the control valve to the line on the tractor marked P1. (To the transmission housing)



LUBRICATION & MAINTENANCE

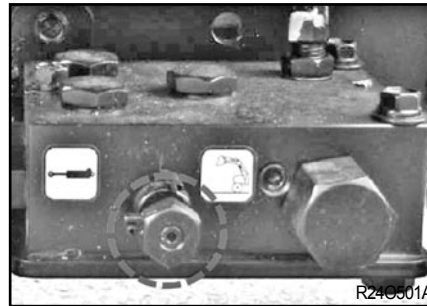
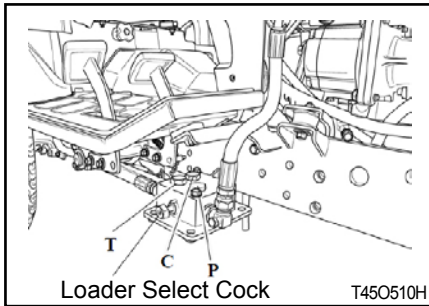

▶ DETACHING THE LOADER

1. Detach the hydraulic hoses of loader.
2. Assemble the cap (PF3/8) with pipe comp (PF3/8).

When is loader installed, the turn clock-wise valve cock. Also when loader is not installed, turn counter clock-wise valve cock.



2. MAINTENANCE AND ADJUSTMENT SCHEDULE

PERIODICAL CHECK AND SERVICE TABLE

○: Check, Top-up or Adjust, ●: Replace, △: Clean or Wash, ★: Consult the Service RK Tractor store

Division	Item	Daily	Service interval (Hour meter, Mark)												1YR	2YR	Comment		
			0 5 0	1 0 0	1 5 0	2 0 0	2 5 0	3 0 0	3 5 0	4 0 0	4 5 0	5 0 0	5 5 0	6 0 0					
1. Engine	Engine oil & Cartridge	○	★					●										Every 250 hours or 12 months after 1st 50 hours	
	Air cleaner	○				○							●						
	Radiator coolant	○															●		
	Fuel	○																Fill tank	
	Fuel filter	○											●						
	Fan belt	○																	
	Battery			○															
	Loose nuts and bolts	○																	Tighten
	Radiator hose clamp	○																	Tighten if required

CAUTION

- These intervals are for operation under normal conditions and need to be reviewed under severe conditions to a greater frequency.



LUBRICATION & MAINTENANCE

○: Check, Top-up or Adjust, ●: Replace, △: Clean or Wash, ★: Consult the Service RK Tractor store

Division	Item	Daily	Service interval (Hour meter, Mark)												1YR	2YR	Comment		
			0 5 0	1 0 0	1 5 0	2 0 0	2 5 0	3 0 0	3 5 0	4 0 0	4 5 0	5 0 0	5 5 0	6 0 0					
2. Chassis	Transmission oil & HST oil filter		★					○							●		●	Every 500 hours or 12 months after 1st 50 hours	
	Oil of the 4WD front axle		★					○								●			●
	Strainer		△						△										
	State of both brake pedals	○																	
	Operation of each lever	○																	Smooth operation
	Free play of steering wheel	○																	About 50 mm (1.97 in) of wheel circumference
	Toe-in							○									○		
	Grease in front wheel hub							○											
	Check the steering wheel joint	○																	
	Wheel nut fastening torque	○																	
	Loose bolts and nuts	○																	Tighten to proper torque

5-8



LUBRICATION & MAINTENANCE



○: Check, Top-up or Adjust, ●: Replace, △: Clean or Wash, ★: Consult the Service RK Tractor store

Division	Item	Daily	Service interval (Hour meter, Mark)												1YR	2YR	Comment	
			0 5 0	1 0 0	1 5 0	2 0 0	2 5 0	3 0 0	3 5 0	4 0 0	4 5 0	5 0 0	5 5 0	6 0 0				
2. Chassis	Operation of the instrument	○																
	Grease each nipple		○	○	○	○	○	○	○	○	○	○	○					
	Check the electric wiring	○																Without loose or broken terminals. Or missing wiring. Correctly clamped.
	Hydraulic hoses & pipes							○										

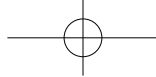

LUBRICATION & MAINTENANCE

3. FILLING DIAGRAM & CAPACITY TABLE

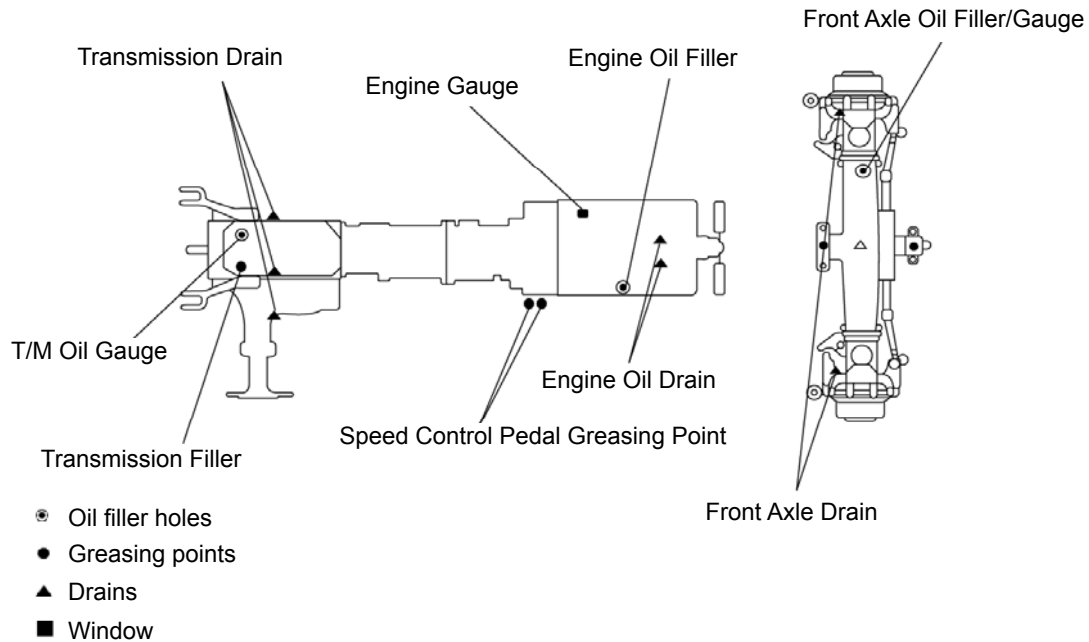

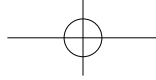

4. LUBRICANTS

No.	Filling point	Fillings	Quantity Liter (gal.)
1	Radiator	Fresh clean water(L.L.C) with an antifreeze, mixed in ratio of minimum 50%	3.6ℓ (0.96US gal)
2	Engine	API : CD/CE grades Above:25°C(77°F)...SAE30 or 10W-30 0°C to 25°C(32°F to 77°F)...SAE20 or 10W30 Below 0°C(32°F)...SAE 10W or 10W-30	2.7 ℓ (0.71 US gal)
3	Transmission	(API GL-4 Grade) Tractor transmission and hydraulic oil Below -4°F(-20°C) ISO VG32 Above -4°F(-20°C) between ISO VG46 and 68	14.5ℓ (3.83 US gal)
4	Front Axle	(API GL-4 Grades)Gear oil #80 or #90	3.2ℓ (0.85 US gal)
5	Front axle pivot pin	Grease	As required
6	Fuel Tank	Diesel fuel	22ℓ (5.81 US gal)

► RECOMMENDED TRANSMISSION OIL

1. RK universal tractor fluid

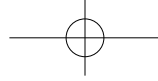

LUBRICATION & MAINTENANCE

5. OPENING METHOD OF EACH COVER

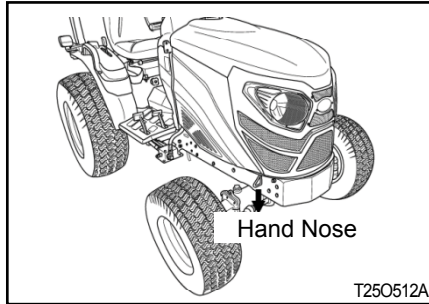

▶ OPENING METHOD OF FAN COVER

Pull the lower center lever of the front grille counter clock wise, pull the lower edges of hood panel upward, and pull the whole panel forward until the guide hook lock is hooked to the groove.

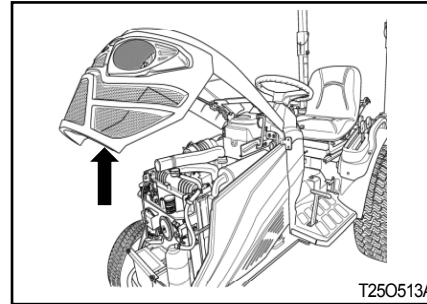

▶ OPENING THE SIDE COVER

To open, grasp the side cover, pull the forward panel upward to separate from guide the support pin (1). And pull the side panel forward again.

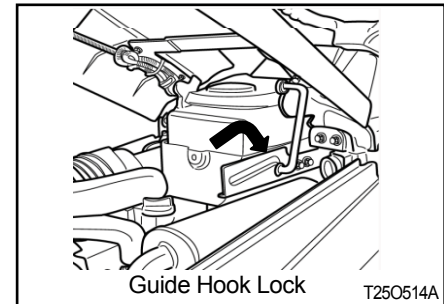
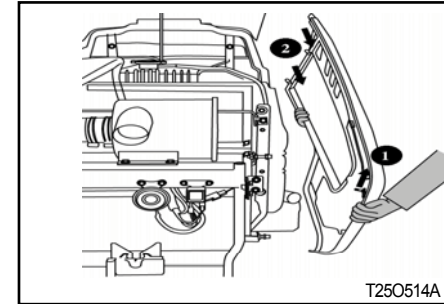

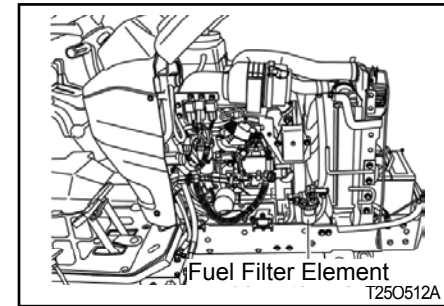
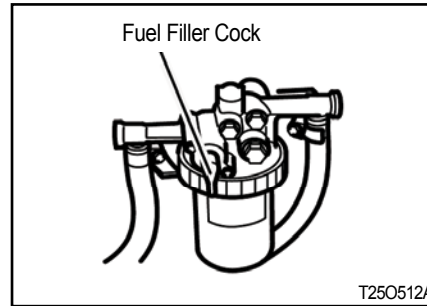
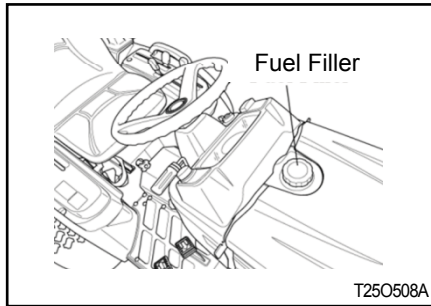

► FUEL

1. Fuel filter cock "ON".
2. Open the cock on the fuel injection pump.
3. Fill the tank with fuel and turn the ignition key to on.
4. Start the engine and allow it to run for a while.
5. Close the fuel injection pump cock.
6. The bleeding of the system is now finished.

► CLEANING THE FUEL FILTER

1. Close the fuel cock.
2. Remove the fuel filter element.
3. Wash the fuel filter element in clean diesel fuel. If necessary, replace it.
4. Fit a cleaned or new fuel filter element.
5. Open the fuel cock.
6. Bleed the fuel system.

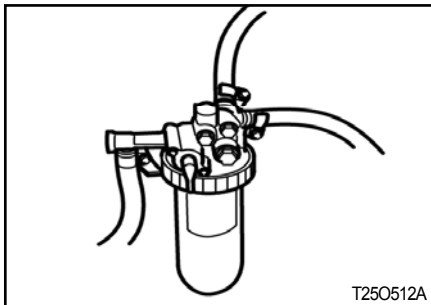
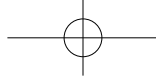

IMPORTANT

- Never use petrol, thinners or any other similar flammable material to clean the Important fuel filter.

▶ CLEANING OIL WATER SEPARATOR

1. Fuel filter cock "ON".
2. Open the cock on the fuel injection pump.
3. Fill the tank with fuel and turn the ignition key to on.
4. Start the engine and allow it to run for a while.
5. Close the fuel injection pump cock.
6. The bleeding of the system is now finished.

6. CHANGING THE OILS IN THE TRACTOR

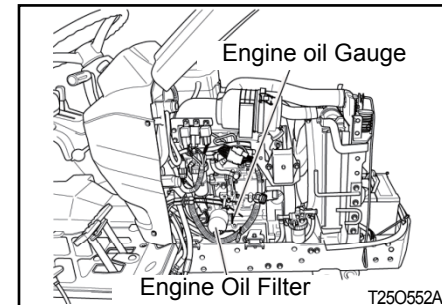

Always use quality oils as engine or transmission oil (Refer to the page 5-3).

Refer to the table on page 5-7, 5-8 and 5-9 for the change frequency.

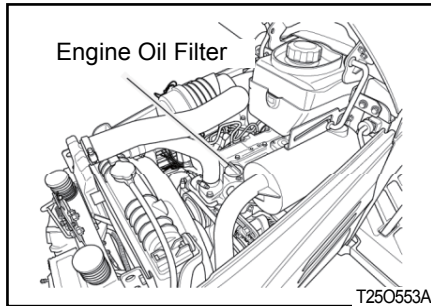

IMPORTANT

- When changing the oil always change the filter.
- Always use the same oil, as using different oils or specifications can cause damage.
- Dispose off the old oil as per local regulations.

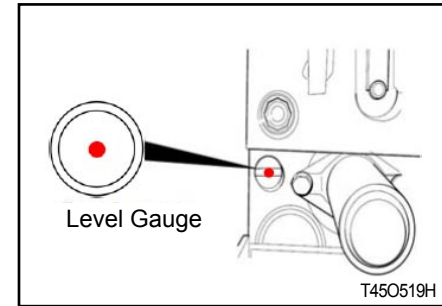

► CHANGING ENGINE OIL

Park tractor on level surface, shut-off engine.

Remove sump plug & drain oil.

Replace and check the sump plug and refill the engine with oil to the correct level on the dipstick. (Approx. 2.7ℓ(0.71 US gal).

The grade of oil to be used will depend on the ambient temperature. See page 5-16, 5-17.

The tractor is shipped from the factory with 10W/30.

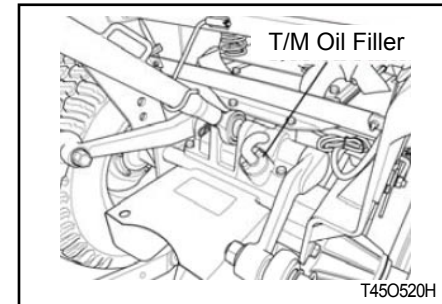

► CHANGING THE TRANSMISSION OIL

1. Allow the transmission oil to cool.

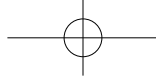

LUBRICATION & MAINTENANCE

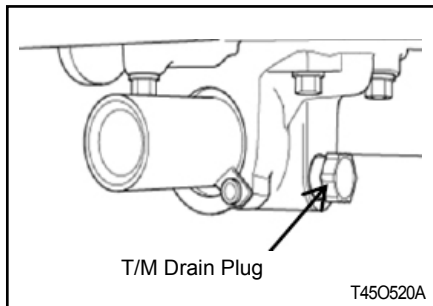

2. Remove the drain plug from bottom of the transmission and drain the oil.
3. Replace and check the drain plug.
4. Refill the transmission to the correct level on the dipstick with new oil: Qty 14.5ℓ (3.83 US gal)

IMPORTANT

- Always use the same grade and specified oil as replacements.
- Dispose off the old oil as per local regulations.

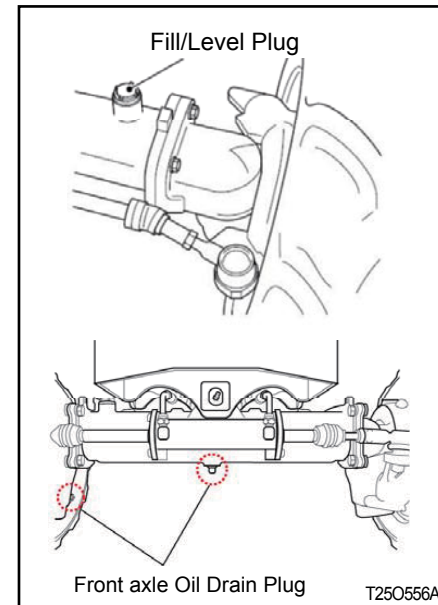

► CHANGING OIL IN THE FRONT AXLE

1. Drain the oil from the center diff plug and the drain plug in each drive.



7. CLEAN AND CHANGE FILTER

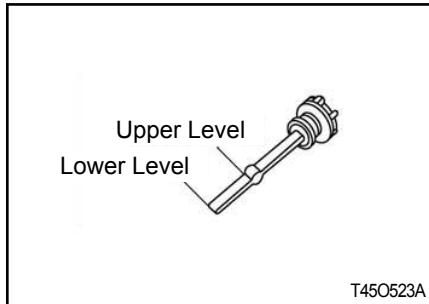

IMPORTANT

- Some operators have found that when they fill with the correct amount of oil and dip it, the oil level on the dipstick is too high due to the fact that it takes a while for the oil to run into the final drives.
- Opening the Vent plugs helps to speed this up.

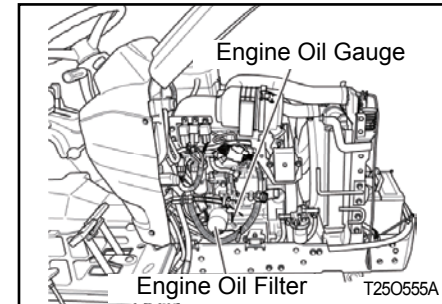

5

2. Replace and tighten all drain plugs.
3. Remove the Fill/Level plug from each final drive to vent air from final drives.
4. Remove the dip stick from the filter hole and fill with front axle oil capacity to 3.2ℓ (0.85 US gal) and allow time for the oil to drain into the final drives.
5. Check the oil level with the dipstick and replace the Fill/Level plugs on both final drives and tighten.

▶ ENGINE OIL FILTER

Using a filter wrench turn the filter anti counter clockwise to remove it. Lightly smear the rubber seal on the new filter with oil to ensure, turn it clockwise until the seal contacts the base and then turn it another 2/3 turn to tighten it.



8. CHANGING THE COOLANT

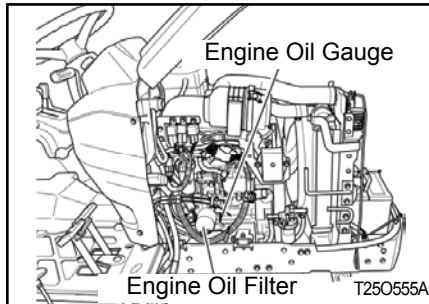

▶ ENGINE OIL FILTER CARTRIDGE

Remove the filter with a filter wrench.

To replace, apply oil or grease on the seal, fit by hand until the seal contacts, then turn it a 2/3rd turn further to tighten it; check for leaks.

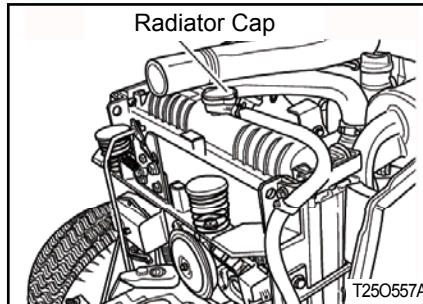

1. Open to drain cock.
2. Open the radiator cap at the same time.
3. To give a thorough clean run a hose into the radiator and flush it out.
4. Close the tap and refill the radiator with a coolant mixture of water and corrosion inhibitor or anti freeze.
5. Start the engine and allow it to run for approx 5 minutes, check the water level again and top up if required.

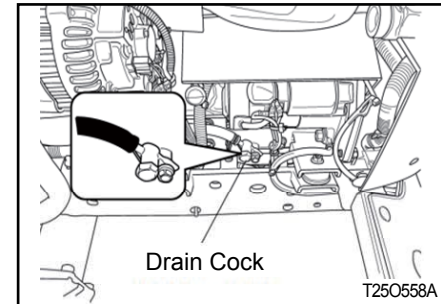

⚠ CAUTION

- Do not remove the radiator cap on a hot engine.
- Allow the engine to cool down and then turn the cap slowly to ensure, that there is no excessive pressure in the radiator.

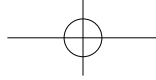

CAUTION

- Serious burns, can result from the contents of pressurized, hot radiators.
- Allow the engine to cool down completely before opening radiator cap.

▶ ANTI FREEZE

Frozen cooling water can damage the engine.

Before replacing the anti freeze solution flush the radiator.

Mix the anti freeze solution in accordance with the instructions applicable to the brand of anti freeze and the locals climate.

Replace the solution in the radiator.

In case of loss of solution due to evaporation or overflow, replace with the original mixture ratio.

IMPORTANT

- Water or air under high pressure can distort the cooling fins on the radiator and reduce its efficiency.

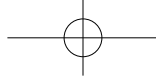

LUBRICATION & MAINTENANCE

9. GREASING THE TRACTOR

Grease the tractor according to the service schedule. (Page 5-7 and 5-8)
Ensure that grease nipples are cleaned well before any attempt is made to grease them.

► FRONT AXLE PIVOT PIN

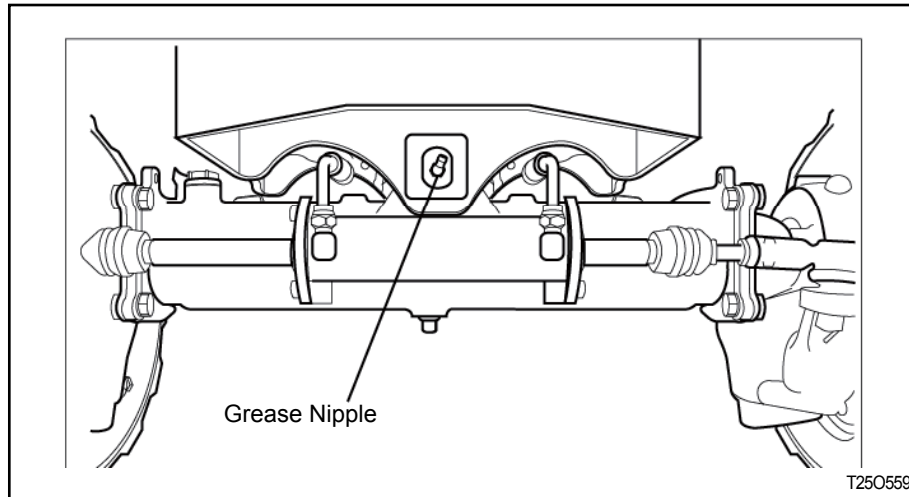

10. GAP ADJUSTMENT

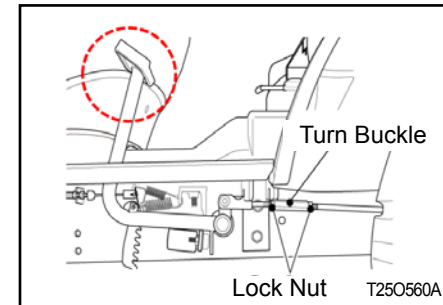

► ADJUSTING THE BRAKES

As is the case with the clutch, use of the brakes will change the pedal free play and the balance between the right and left pedal.

The correct pedal free play is 1.18~1.57 in. (30~40 mm).

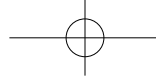

▶ ADJUSTMENT METHOD

Loosen the locknuts to adjust the brake.

Turn the turnbuckle counterclockwise to increase the free play, or turn the turnbuckle clockwise to decrease.

Tighten the locknut and confirm, to fix the nuts.

Check that the free play is correct and the same on both pedals to ensure even braking.

⚠ CAUTION

- Uneven adjustment of the left and right pedal will result in one sided braking when the pedals are connected and can cause serious accidents, especially at high speeds.
- Double check to ensure free play is the same on both pedals.

▶ ADJUSTING THE THROTTLE LEVER

If this lever is either loose or difficult to move please consult your RK Tractor store for rectification of the problem.



LUBRICATION & MAINTENANCE

11. BATTERY MAINTENANCE

▶ ADJUSTING TOE-IN

If the toe-in adjustment is incorrect it can cause severe shaking of both the steering wheel and the entire tractor.

The correct toe in is 0.08~0.24 in. (2~6 mm) We recommend that this adjustment is made by the RK Tractor store.

▶ BATTERY MAINTENANCE

Low temperatures will affect the performance of batteries so take particular care of it in winter.

For long-term storage of the tractor remove the battery and keep it in a cool dry room.

If it is on the tractor while stored, disconnect the negative terminal.

Batteries will self discharge if left for a period of without use time.

To keep them in good condition charge them once a month in summer and every second month in winter.

When replacing the original battery, ensure that the replacement battery is the same size.

Failure to do so can cause problems with the electrical circuit.

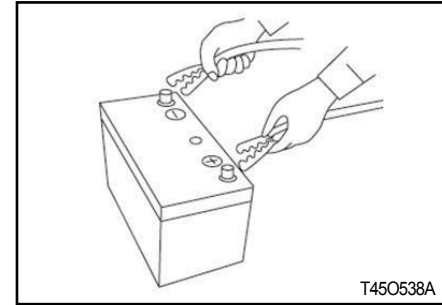

▶ BATTERY CHARGING

A boost charge is only for emergencies. It will partially charge the battery at a high rate and in a short time.

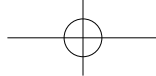

12. FAN BELT ADJUSTMENT

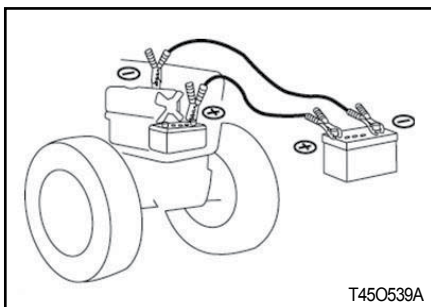

When using a boost-charged battery, it is necessary to recharge the battery as early as possible.

Failure to do this will shorten the battery's service life.

CAUTION

- Always disconnect the negative terminal first when removing the battery and always connect the positive terminal first when fitting the battery.
- When connecting the battery leads make sure not to reverse the polarity.
- Quick charging will reduce battery life.
- Disconnect the terminals prior to charging the battery to avoid damage to the circuit and electrical instruments.

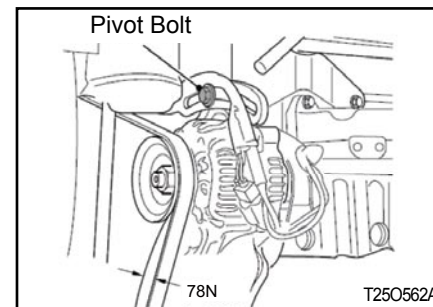

5

1. Loosen the alternator pivot bolt.
2. Move the alternator in order to increase or decrease the belt tension. Tighten the alternator pivot bolt and the link bolt to 22 N.m (16 lb ft) (1).



LUBRICATION & MAINTENANCE

13. SERVICE THE AIR CLEANER

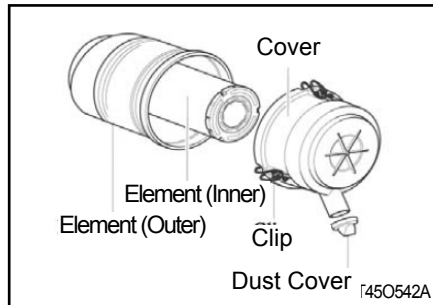

▶ CLEANING THE AIR CLEANER DUST VALVE

Check that the dust valve is not blocked.

Inspect the rubber flaps for cuts and nicks and check that the rubber is not perished. Renew if necessary.

To remove dust from the dust valve, squeeze it between thumb and fingers. Wipe around the dust valve to remove dust collected on the outside.

▶ CLEANING/CHANGING THE ELEMENT

Release the two clips on the air cleaner end cover and remove the element.

Remove dust by blowing compressed air through the element.

Check the element for damage, if necessary, change the elements.

Check all hoses for condition and tightness.

⚠ IMPORTANT

- Never beat the element on a stone or concrete floor/wall to clean it.
- Check all connections and hoses especially on the clean side of the air cleaner to ensure no dusty air can enter the engine.
- Check the element for flaws by putting a light inside the element.
- When reassembling make sure all surfaces seal correctly to keep dust out.
- When working in dusty conditions increase the service frequency.

※ Replace the element after cleaning it 5 times or it is damaged.



▶ CHECKING HOSES AND LINES

The fuel lines, radiator hoses, hydraulic and rubber hoses are consumables which deteriorate by age and use.

Check them regularly and replace if faulty.

CAUTION

- Damaged fuel lines leak and cause fires.
- Damaged radiator hoses can cause hot water burns and in severe cases seize the engine.

▶ CHECKING THE WIRING HARNESS AND FUSES

Loose wires make inferior connections and damaged wires can cause short circuits, fires burnt wiring or reduce efficiency of components.

Replace or repair any faulty wiring or insulation.

If a fuse burns out again after it has been replaced, do not replace it with wire or a high capacity fuse, find the cause and rectify it or get an auto electrician to do so.

Where insulation is chafed or peeled off, recover the area with a good quality insulation tape. Where wiring comes out of it's fitting replace it correctly with the standard fitting.

IMPORTANT

- Incorrect wiring or fuses can cause fires to both the tractor and surrounding area so get the RK Tractor store to check it annually.
- Likewise fuel pipes and wiring age with use.
- Ask your RK Tractor store to check it at least once every 2 years and replace as required.

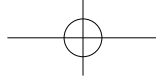

LUBRICATION & MAINTENANCE

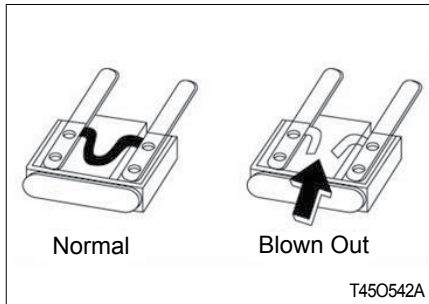

▶ REPLACING FUSES

The circuit has 8 blade type fuses in its wiring circuit.

When a fuse has blown replace it with one of the same value.

Using a large capacity fuse or wire burn out the wiring system.

Use fuse tongs to replace fuses.

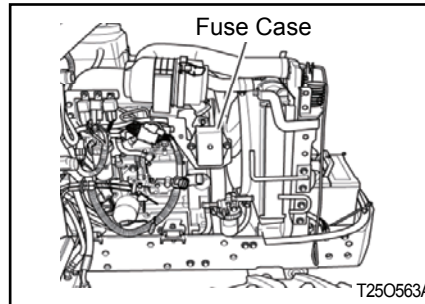

▶ MAIN FUSES

The wiring harness is equipped with 3 main fuses who's function is to preserve the wiring.

However when a main fuse blows the entire circuit is dead.

Always check the reason & rectify before replacing the fuse of the same value.

To indicate that the fuse is blown it will be discolored.

⚠ IMPORTANT

- Always check the reason for a blown fuse otherwise the new fuse is also likely to blow.

Never ever use wire in place of correct grade fuse.

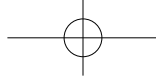

14. STORAGE

► SERVICE PRIOR TO DAILY AND SHORT TERMS STORAGE

Wash the tractor and keep it clean.
Fill the tank to avoid condensation and rust.
Lower any attached implement to the ground before parking the tractor.
For long-term storage consult your RK Tractor store.

► FOR DAILY OR SHORT TERM STORAGE

Clean the tractor and remove all dirt from field work.
Fill the fuel tank to avoid condensation and rust.
Lower the implement to the ground.
Keep it in a machinery shed or, if not available cover the unit if left outside.
In very cold conditions it is advisable to remove the battery and keep it inside in a warm environment.
This will ensure effective starting when the tractor is required.
When the outside temperature is below 32°F (0°C), replace the Anti-freeze completely or drain the coolant to protect the engine from damage from frozen coolant.

⚠ IMPORTANT

- When washing the tractor ensure that the water does not get near electrical components or the oil filter points.
- To prevent short circuits remove the ignition key.
- Do not wash the tractor when the engine is running.



LUBRICATION & MAINTENANCE

▶ LONG-TERM STORAGE.

When the tractor will not be used for a long time carry out the cleaning as for short term storage.

Drain the oil and replace with new oil.

Run the engine for approx. 5 min. to ensure that it has new oil throughout the engine.

Drain the coolant from the radiator and remove the ignition key.

Attach a tag both the key and the steering wheel saying "No coolant".

Lubricate all grease and oil points on the tractor.

Check the pressures and add a small amount of extra pressure.

Lower any implement to the ground or store in a shady dry place.

Place a piece of wood under each tire to preserve the tire.

IMPORTANT

- After refilling the engine with the coolant run the engine for approx. 5-10 min. at 1,500~2,000 rpm every month as a corrosion prevention measure.
- Either removes the battery or the negative terminal as mouse damage to wiring can cause short circuits and fires.
- Remove the ignition key and store in a safe place.

▶ RE-USE AFTER LONG TERM STORAGE.

Carry out a full check of all oils and coolant.

Refit the battery and run the engine at idle for 30 min. to ensure optimum engine life.

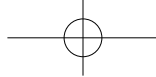

15. FUEL SAVING TIPS

To save fuel & oil in your tractor, following things should always be kept in mind.

► AIR CLEANING SYSTEM

1. Clean the air cleaner regularly so that dust does not settle down.
2. For every 50 hours & everyday in sandy/dusty conditions.
 - Clean the air cleaner filter element with compressed air.
 - If the rubber ring is cut or expanded then change it with an appropriate one. Fix the rubber at the proper location & check for leakages if any.
 - If air is leaking through the hose connection, check & rectify other leakages, too.

NOTE

- If air cleaning system is not properly maintained, it will lead to early wear of piston rings & sleeves. This will lead to problems like loss of engine power, excessive oil consumption fuel consumption.

► ENGINE

1. Put the engine oil on load after the engine is heated & the water temperature gauge indicates the needle to be in the green zone.
2. If excessive black smoke is visible, then the paper element of air cleaner, Fuel injection pump or nozzles should be checked.
3. Do not run the engine without load for more than 2 minutes. It is better to stop the engine rather than run it idle. This will help in saving of fuel.



LUBRICATION & MAINTENANCE

► BRAKES

1. Do not over ride the brake pedals.
2. While coming down from a slope, reduce the engine throttle & use low gear.
Do not depend only on the brakes for stoppage.

► FUEL SYSTEM

1. Always use filtered diesel for the fuel system.
2. At the end of the day's working, it is preferable to fill the diesel tank so that it may prevent condensation.
3. Change the filter, if the system gets choked. Do not change both the filters at the same time. If the above directives are not adhered to, the fuel injection pump & injection nozzle will lose its life early. Also, it will lead to excessive black smoke & excessive diesel consumption.

► ENGINE SYSTEM

1. Always use recommended grade of oil.
2. Everyday before starting the engine, check the oil level with a dipstick & refill between the minimum & maximum level.
3. Change the engine oil. Replace filter & "O" ring, as & when required.

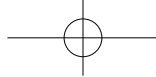

► COOLING SYSTEM

1. Check the fan belt tension regularly. Adjust, if required.
2. Check the coolant level in the radiator fins always clean.
3. Replace the radiator cap with a genuine cap only, if required.
4. Do not remove the thermostat but replace with a new one, if required.
5. Do not change the radiator water often.

NOTE

- Always stop any fuel or oil leakages.
- Carry out the regular maintenance failure to do so might increase the fuel consumption by 25%.
- Carry out the torque of cylinder head bolt & adjustment of valve clearance regularly. Consult your RK Tractor store for this.

NOTE

- Check the tire pressure & inflate, as recommended.
- Always buy genuine spares from the authorized RK Tractor store
- Always carry out the service of the tractor by your authorized RK Tractor store.

※ For any other information, contact your nearest Authorized RK Tractor store.

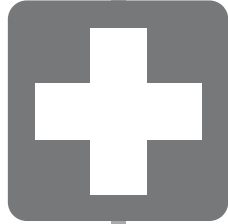

SPECIFICATION

1. SPECIFICATIONS..... 6-2

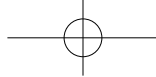

SPECIFICATION

1. SPECIFICATIONS

The specifications on the following pages are given for your information and guidance. For further information concerning your Tractor and equipment, consult your Authorized RK Tractor store.

RK Tractors policy is one of continuous improvement and the right to change prices, specifications or equipment at any time without notice is reserved.

All data given in this book is subject to production variations. Dimensions and weights are approximate only and the illustrations do not necessary show Tractors in standard condition. For exact information about any particular Tractor, please consult your RK Authorized RK Tractor store.

	ITEM	DESCRIPTION	REMARKS
1. Engine	Maker	Yanmar	
	Model	3TNV80F-SDKTFF	
	Type	Water cooled, 4-cycle Diesel	
	Rated Output	17.8 kW(24.2 PS) / 3,000 rpm	
	Number of Cylinder	3	
	Displacement	1,267 cc	
	Bore and Stroke	80mm x 84mm (3.15 in. x 3.31 in.)	
	Rated Speed	3,000 rpm	
	Rated Speed	2,800 rpm	
	High idle rpm	3,235 ± 50 rpm	
	Low idle rpm	1,350 ± 50 rpm	
	Accelerator	Hand Accelerator	
	Compression ratio	23.1 : 1	

6-2

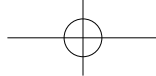

SPECIFICATION



ITEM		DESCRIPTION	REMARKS
1. Engine	Firing order	1 - 3 - 2 - 1	
	Injection pump	Indirect	
	Lubrication type	Forced feed	
	Cooling system	Water cooled, Forced circulation	
	Coolant capacity	3.6 ℓ (0.95 US gal)	
	Air cleaner	Single element	
	Muffler	Horizontal	
	Fuel Tank capacity	22 ℓ (5.8 US gal)	
2. Electrical	Battery	12 Volt 80 H	
	Starting system	Starter motor with pre-heater	
	Starter Capacity	1.2 kW	
	Alternator	12V 40A	
3. Drive Train	Transmission	Hydraulic + Mechanical H/L with constant-mesh	
	MFWD (4WD)	Standard	
	Differential lock	Bevel gears with diff-Lock	
4. Brake	Wet Disc, Foot operated, independent with provision of inter lock for simultaneous operation.		
	Inner dia.	3.03 in. (77 mm)	
	Outer dia.	4.90 in (124.5 mm)	



SPECIFICATION

ITEM		DESCRIPTION	REMARKS
4. Brake	Number of lining	2 each side	
	Brake thickness	0.27mm(0.13 in.)	
5. PTO	Type	Independent PTO	
	Rear	Shaft	6 Splines, 35 mm(1 $\frac{1}{8}$ in.)
		Speed	540 rpm @ 2,893 rpm
	Mid	Shaft	15 Splines , 25.4 mm(1 in.)
Speed		2,000 rpm @ 2,875 rpm	
6. Hydraulic	Steering	Hydrostatic	
	Pump capacity	26.3 lpm (6.95 US gpm)	
	Main Relief pressure	15.2 Mpa (2205 psi)	
	Steering Relief Pressure	10.8 Mpa (1566 psi)	
7. Hitch	3point linkage Category	Cat. 1(N)	
	Lift capacity	600 kg (1323 lb) @ hitch	
8. Dimensions (Turf Tire)	Overall length	100.5 in. (2553 mm)	
	Overall width	45.8 in. (1164 mm)	
	Overall Height	91.3 in.(2320 mm)	
	Wheel base	57.5 in. (1460 mm)	
	Min. Ground Clearance	9.4 in. (240 mm)	
	Weight	730 kg (1610 lb)	



SPECIFICATION



MODEL		RK24H		REMARKS
9. Tire	Ag Tires	Front	6-12	
		Rear	9.5-16	
	Turf Tires	Front	20 x 8-10	
		Rear	29 x 12.5-15	
	Industrial Tires	Front	20 x 8-10	
		Rear	27 x 12.5-15	

※ The specifications are subject to change for improvement without notice.



SPECIFICATION

▶ SPEED CHART (ENGINE RATED SPEED)

Km/h

	Ag Tires	Turf Tires	Industrial Tires
L	6.8	5.9	5.6
H	16.9	14.7	14.1

※ The specifications are subject to change for improvement without notice.



TROUBLESHOOTING

1. TROUBLESHOOTING.....7-2

**1. TROUBLESHOOTING****▶ FAULT TRACING**

SYMPTOM		CAUSE	REMEDY
1. Engine	Turning the main switch will not operate the starter	• Battery flat	• Charge or replace the battery • RK Tractor store to repair or replace
		• Switch faulty	• Contact RK Tractor store for repair or replace
	Starter operates but not enough to turn the engine	• Low battery	• Charge the battery
		• Bad earth	• Clean the earth lead and tighten
		• Thick oil	• Drain and replace with correct oil
	Starter operates OK but does not start the engine	• Air in fuel system	• Bleed the system
		• Clogged fuel filter	• Clean or replace both filters
		• No fuel being supplied	• Fill tank or turn tap on
		• Glow plug disconnected or not working	• Contact RK Tractor store for repair.
	Engine revolutions are irregular	• Air in the fuel system	• Bleed the system
		• Faulty injector	• Contact RK Tractor store for repair.
		• Fuel pipe leak	
	The engine stops at low revolution	• Poor fuel injection	• Contact RK Tractor store for repair
		• Faulty injection pump	• Contact RK Tractor store for repair
		• Wrong valve clearance	• Contact RK Tractor store for repair
		• Wrong idle setting	• Contact RK Tractor store for repair
		• Faulty injector	• Contact RK Tractor store for repair
	The engine stops suddenly	• Lack of fuel	• Fill the tank and bleed the fuel system
• Faulty injectors		• Contact RK Tractor store for repair	
• Seized engine due to lack of oil, the wrong oil or lack of coolant			



SYMPTOM		CAUSE	REMEDY
1. Engine	The engine overheats	• Lack of coolant	• Refill with coolant
		• Broken or misadjusted fan belt	• Adjust or replace
		• Clogged air filter element	• Clean or replace air filter
		• Clogged radiator	• Clean the core
		• Low oil	• Replace the oil to correct grade
	White smoking from the exhaust	• Oil level too high	• Reduce to correct quantity
		• Shortage of or faulty fuel	• Contact RK Tractor store for repair
	Reduced performance of the engine	• The injectors are clogged, carbon coated and sticking	• Contact RK Tractor store for repair
		• Low compression	
		• Leaking valve seat	• Contact RK Tractor store for repair
		• Incorrect valve gap	• Contact RK Tractor store for repair
		• Faulty timing	• Contact RK Tractor store for repair
		• Fuel shortage	• Contact RK Tractor store for repair • Fill the tank and check fuel quality
		• Clogged air cleaner	• Clean the element
	Oil warning light comes on with the engine running	• Low oil level	• Fill to correct level
		• Wrong oil	• Change to correct oil
		• Faulty light or switch	• Replace faulty part
		• Clogged oil filter	• Contact RK Tractor store for repair
	Alternator light comes on with the engine running	• Wiring fault	• Contact RK Tractor store for repair
		• Faulty alternator	• Contact RK Tractor store for repair
• Low water level or faulty battery		• Top up or replace	
• Broken or loose fan belt		• Replace or adjust	



TROUBLESHOOTING

SYMPTOM		CAUSE	REMEDY
2. Brake	Brake not working	<ul style="list-style-type: none"> • Incorrect free play Worm or burnt lining • Left and right gap different 	<ul style="list-style-type: none"> • Adjust to correct free play. Contact RK Tractor store for repair
	Brake pedal not returning	<ul style="list-style-type: none"> • Faulty return spring • Lack of grease on the joints 	<ul style="list-style-type: none"> • Replace spring • Remove rust and lubricate with grease
3. Hydraulic system	Hydraulics are not lifting	<ul style="list-style-type: none"> • Engine revs. too low 	<ul style="list-style-type: none"> • Increase engine revs.
		<ul style="list-style-type: none"> • Lack of transmission Oil 	<ul style="list-style-type: none"> • Top up the oil to the correct level
		<ul style="list-style-type: none"> • Air leaking in from a pipe 	<ul style="list-style-type: none"> • Repair or replace pipe or replace O-ring on joint and tighten
		<ul style="list-style-type: none"> • Clogged suction filter 	<ul style="list-style-type: none"> • Clean and change oil
		<ul style="list-style-type: none"> • Faulty pump 	<ul style="list-style-type: none"> • Contact RK Tractor store for repair
		<ul style="list-style-type: none"> • Faulty hydraulic valve 	<ul style="list-style-type: none"> • Contact RK Tractor store for repair
	Oil leak from pipe	<ul style="list-style-type: none"> • Loose pipe joint • Cracked pipe 	<ul style="list-style-type: none"> • Tighten joint • Replace or repair pipe
When lifting the relief valve whistles	<ul style="list-style-type: none"> • The stopper has slipped down 	<ul style="list-style-type: none"> • Adjust the stopper 	
For any other hydraulic problems please consult your RK Tractor store who has the correct equipment to diagnose and repair the system			



SYMPTOM		CAUSE	REMEDY
4. Steering wheel	Steering wheel shaking	• Wrong toe-in	• Adjust toe-in
		• Unequal tire pressure	• Inflate both to correct pressure
		• Loose component	• Tighten or replace if worn
	Excessive play in the steering	• Worn steering shaft	• Contact RK Tractor store for repair
• Worn components		• Contact RK Tractor store for repair	
5. Electric instruments	Flat battery	• Faulty wiring	• Repair, Reconnect or tighten as needed
		• Faulty alternator	• Contact RK Tractor store for repair
		• Faulty regulator	• Contact RK Tractor store for repair
		• Broken or loose fan belt	• Replace or adjust
	Before anything else, check the electrolyte level of the battery and the connections. Top up it required and clean and retighten the terminal		
Dim head lights	• Low battery	• Charge or replace	
	• Faulty wiring	• Repair or replace as needed	
Headlights not working	• Blown bulb	• Replace bulb	
	• Blown fuse	• Replace fuse	
	• Faulty contact	• Repair or replace and check the earth	
Horn not working	• Faulty horn button	• Replace button	
	• Faulty wiring	• Repair or replace	
	• Faulty horn	• Replace	
Indicator not working	• Blown bulb	• Replace bulb	
	• Faulty flasher unit	• Replace unit	
	• Faulty wiring	• Repair or replace	



TROUBLESHOOTING

MEMO

Dotted lines for memo writing

7-6

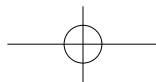



APPENDIX

- 1. DRAWING FOR FIXING POSITION OF THE FUSE ... 8-2
- 2. WIRING DIAGRAM OF THE ELECTRIC INSTRUMENT 8-3
- 3. TRACTOR HISTORY CARD 8-4
- 4. SERVICE RECORD 8-5
- 5. DAILY OPERATION LOG 8-6
- 6. PART REPLACEMENT RECORD 8-7



APPENDIX

1. DRAWING FOR FIXING POSITION OF THE FUSE

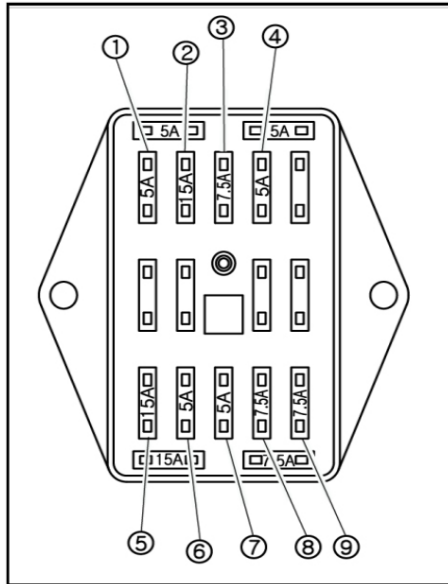

T450907A

①	Hazard	5A
②	Coupler	15A
③	EG Stop, PTO	7.5A
④	Glow Timer	5A
⑤	Light, Horn	15A
⑥	Panel	5A
⑦	Turn Signal	5AW
⑧	Working Light	7.5A
⑨	Stop Lamp , Cruise	7.5A



2. WIRING DIAGRAM OF THE ELECTRIC INSTRUMENT

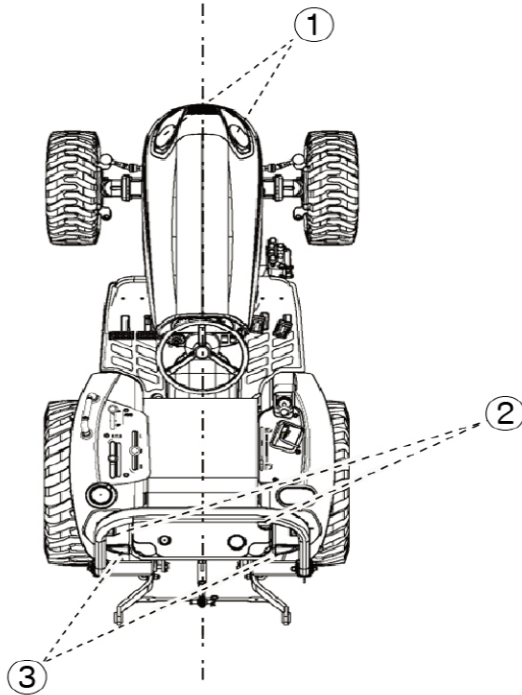

①	Head Lamp	12V/ 55W
②	Combination Lamp	12V/ 21W/ 5W
③	Stop Lamp	12V/ 21W/ 5W

T45O908A



APPENDIX

3. TRACTOR HISTORY CARD

DATE	JOB CARD NO.	NATURE OF DEFECT	PARTS REPLACEMENT	W/CLAIM NO. AND DATE	REMARKS

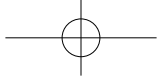

4. SERVICE RECORD

DATE	TRACTOR HOURS	NATURE/TYPE OF REPAIR/SERVICE CARRIED OUT

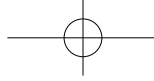

APPENDIX

5. DAILY OPERATION LOG

DATE	JOB DONE	MACHINE HOURS		FUEL CONSUMPTION	ENGINE OIL TOPPED UP	REMARKS
		START	END			

8-6

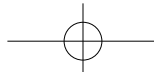

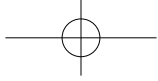

6. PART REPLACEMENT RECORD

DATE	PART DESCRIPTION	QTY	COST	DATE	PART DESCRIPTION	QTY	COST



APPENDIX

MEMO

Lined area for writing notes

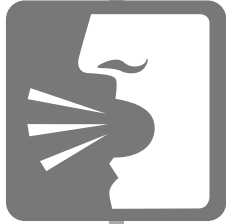

WARRANTY

- 1. YANMAR WARRANTIES9-2
- 2. EMISSION SYSTEM WARRANTY9-5
- 3. RK WARRANTY.....9-9

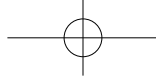

WARRANTY

1. YANMAR WARRANTIES

YANMAR LIMITED WARRANTY

▶ WHAT IS COVERED BY THIS WARRANTY?

YANMAR warrants to the original retail purchaser that a new **YANMAR** TNV common rail series industrial engine will be free from defects in material and/or workmanship for the duration of the warranty period.

Note: **YANMAR** engines may be equipped with external components including, but not limited to: wiring harnesses, electrical devices, control panels, radiator, air filters, fuel/ or exhaust systems that are supplied and/or installed by manufacturers other than **YANMAR**. For warranty information on such external components, please contact the machine or component manufacturer directly or see your authorized **YANMAR** dealer or distributor.

This warranty is provided in lieu of all other warranties, express or implied. **YANMAR** specifically dis-

claims any implied warranties of merchantability or fitness for a particular purpose, except where such disclaimer is prohibited by law. If such disclaimer is prohibited by law, then implied warranties shall be limited in duration to the life of the express warranty.

▶ HOW LONG IS THE WARRANTY PERIOD?

The **YANMAR** standard limited warranty period runs for a period of twenty-four (24) months or Two-thousand(2000) engine operation hours, whichever occurs first. An extended limited warranty of thirty-six(36) months or three thousand(3000) engine operating hours, whichever occurs first, is provided for these specific parts only: the cylinder block, cylinder head, crankshaft forging, connecting rods, flywheel, flywheel housing, camshaft, timing gear, and gear case. The

warranty period for both the Standard limited warranty and the extended limited warranty (by duration or operation hours) begins on the date of delivery to the original retail purchaser and is valid only until the applicable warranted duration has passed or the operation hours are exceeded, whichever comes first.

**WHAT THE ENGINE OWNER MUST DO:**

If you believe your **YANMAR** engine has experienced a failure due to a defect in material and/or workmanship, you must contact an authorized **YANMAR** industrial engine Dealer or distributor within thirty (30) Days of discovering the failure. You must provide proof of ownership of the engine, proof of the date of the engine purchase and delivery, and documentation of the engine operation hours. Acceptable forms of proof of delivery date include, but are not limited to: the original warranty registration of sales receipts or other documents maintained in the ordinary course of business by **YANMAR** Dealers and/or distributors, indicating the date of delivery of the **YANMAR** product to the original retail purchaser. This information is necessary to establish whether the **YANMAR** product is still within the warranty period. Thus, **YANMAR**

strongly recommends you register your engine as soon as possible after purchase in order to facilitate any future warranty matters.

You are responsible for the transportation of the engine to and from the repair location as designated by **YANMAR**.

▶ TO LOCATE AN AUTHORIZED YANMAR INDUSTRIAL ENGINE DEALER OR DISTRIBUTOR:

You can locate your nearest authorized **YANMAR** industrial engine Dealer or distributor by visiting the **YANMAR** Co., Ltd. Website at:

<http://www.yanmar.co.jp> (The Japanese language page will be displayed.) For English language “click” on “English Page.”)

- “click” on “Network” in the website heading to view the “**YANMAR** Worldwide Network”.
- Choose and “Click” on the desired

product group.

- “Click” on the Icon closest to your region.
- “Click” on the desired country or associate company to locate your nearest authorized **YANMAR** Industrial engine Dealer or distributor.

You may also contact **YANMAR** by clicking on “Inquiry” in the website heading and typing in your question or comment.

What **YANMAR** will DO:

YANMAR warrants to the original retail purchaser of a new **YANMAR** engine that **YANMAR** will make

such repairs and/or replacements at **YANMAR**'s option, of any part(s) of the **YANMAR** product covered by this warranty found to be defective in material and/or workmanship. Such repairs and/or replacements will be made at a location designated by **YANMAR** at no cost to the purchaser for parts or labor.



WARRANTY

WHAT IS NO COVERED BY THIS WARRANTY?

This warranty does not cover parts affected by or damaged by any reason other than defective materials or workmanship, including, but not limited to, accident, misuse, abuse, "Acts of God," neglect, improper installation, improper maintenance, improper storage, the use of unsuitable attachments or parts, the use of contaminated fuels, the use of fuels, oils, lubricants, or fluids other than those recommended in your **YANMAR** Operation Manual, unauthorized alterations or modifications, ordinary wear and tear, and rust or corrosion. This warranty does not cover the cost of parts and/or labor required to perform normal/scheduled maintenance on your **YANMAR** engine. This warranty does not cover consumable parts such as, but not limited to, filters, belts, hoses, fuel injector, lubricants and cleaning fluids. This warranty does not cover

the cost of shipping the product to or from the warranty repair facility.

► WARRANTY LIMITATIONS:

The foregoing is YANMAR's only obligation to you and your exclusive remedy for breach of Warranty. Failure to follow the requirements for submitting a claim under this warranty may result in a waiver of all claims for damages and other relief. In no event shall YANMAR or any authorized Industrial engine Dealer or distributor be liable for incidental, special or consequential damages.

Such consequential damages may include, but not be limited to, loss of revenue, loan payments, cost of rental of substitute equipment, insurance coverage, storage, lodging, transportation, fuel mileage, and telephone costs. The limitations in this warranty apply regardless of whether your claims are based on

breach of contract, tort (including negligence and strict liability) or any other theory. Any action arising hereunder must be brought within one (1) year after the cause of action accrues or it shall be barred. Some states and countries do not allow certain limitations on warranties or for breach of warranties. This warranty gives you specific legal rights, and you may also have other rights which vary from state to state and country to country. Limitations set forth in this paragraph shall not apply to the extent that they are prohibited by law.

► WARRANTY MODIFICATION

Except as modified in writing and signed by the parties, this warranty is and shall remain the complete and exclusive agreement between the parties with respect to warranties, superseding all prior agreements, written and oral, and all other communications between the



2. EMISSION SYSTEM WARRANTY

parties relating to warranties. No person or entity is authorized to give any other warranty or to assume any other obligation on behalf of **YANMAR**, either orally or in writing.

► QUESTIONS:

If you have any questions or concerns regarding this warranty, please call or write to the nearest authorized **YANMAR** industrial engine Dealer or distributor or other authorized facility.

YANMAR CO., LTD. LIMITED EMISSION CONTROL SYSTEM WARRANTY – USA ONLY

► YOUR WARRANTY RIGHTS AND OBLIGATIONS:

[CALIFORNIA]

The California Air Resources Board (CARB), the Environmental Protection Agency (EPA) and **YANMAR** Co., Ltd. hereafter referred to as **YANMAR**, are pleased to explain the emission control system warranty on your industrial compression-ignition engine. In California, model year 2000 or later off-road compression-ignition engines must be designed, built and equipped to meet the state's stringent anti-smog standards. In all states, 1998 and later non-road compression-ignition engines must be designed, built and equipped to meet the United States EPA emissions standards. **YANMAR** warrants the emission control system on your engine for the periods

of time listed below provided there has been no abuse, neglect or improper maintenance of your engine.

Your emission control system may include parts such as the fuel injection system, the air induction system, the electronic control system, EGR(Exhaust Gas Recirculation) system and Diesel Particulate Filter. Also included may be hoses, belts, connectors and other emission-related assemblies.

Where a warrantable condition exists, **YANMAR** will repair your non-rod compression-ignition engine at no charge to you including diagnosis, parts and labor.

► MANUFACTURER'S WARRANTY PERIOD:

The model year 1998 or later certified and labeled non-road compression-ignition engines are warranted

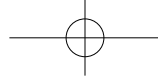

WARRANTY

for the periods listed below. If any emission-related part on your engine is found to be defective during the applicable warranty period, the part will be replaced by **YANMAR**.

If your engine is certified as	And its maximum Power is	And its rated speed is	Then its warranty period is
Variable speed or Constant speed	kW<19	Any speed	1,500 hours or two (2) years whichever comes first. In the absence of a device to measure the hours of use, The engine has a warranty period of two(2) years.
Constant speed	19 < kW < 37	3,000rpm or higher	1,500 hours or two (2) years whichever comes first. In the absence of a device to measure the hours of use, The engine has a warranty period of two(2) years/
Constant speed	19 < kW <37	Less than 3,000rpm	3,00hours of five (5) years whichever comes first. In the absence of a device to measure the hours of use, the Engine has a warranty period of five(5) years.
Variable speed	19 < kW <37	Any speed	3,000 hours or five (5) years whichever comes first. In the absence of a device to measure the hours of use, the engine has a warranty period of five (5) years.
Variable speed or Constant speed	kW > 37	Any speed	3,000 hours or (5) years whichever comes first. In the absence of a device to measure the hours of use, The engine has a warranty period of five (5) years.



► WARRANTY COVERAGE:

This warranty is transferable to each subsequent purchaser for the duration of the warranty period. Repair or replacement of any warranted part will be performed at an authorized **YANMAR** industrial engine Dealer or distributor.

Warranted parts not scheduled for replacement as required maintenance in the operation manual shall be warranted for the warranty period. Warranted parts scheduled for replacement as required maintenance in the operation manual are warranted for the period of time prior to the first scheduled replacement. Any part repaired or replaced under warranty shall be warranted for the remaining warranty period.

During the warranty period, **YANMAR** is liable for damages to other engine components caused by the failure of any warranted part during the warranty period.

Any replacement part which is functionally identical to the original equipment part in all respects may be used in the maintenance or repair of your engine, and shall not reduce **YANMAR**'s warranty obligations.

Add-on or modified parts that are not exempted may not be used, The use of any non-exempted add-on or modified parts shall be grounds for disallowing a warranty.

[WARRANTED PARTS]

This warranty covers engine components that are a part of the emission control system of the engine as Delivered by **YANMAR** to the original retail purchaser, Such components may include the following:

- Fuel injection system
- Electronic control system
- Cold start enrichment system

- Intake manifold
- Turbocharger systems
- Exhaust manifold
- EGR system
- Positive crankcase ventilation system
- Hoses, belts, connectors and assemblies associated with emission control systems
- Exhaust gas after treatment (Diesel Particulate Filter (DPF))

Since emissions-related parts may vary slightly between models, certain models may not contain all of These parts and other models may contain the functional equivalents.

► EXCLUSIONS:

Failures other than those arising from defects in material and/or workmanship are not covered by this warranty. The warranty does not



WARRANTY

extend to the following: malfunctions caused by abuse, misuse, improper Adjustment, modification, alteration, tampering, disconnection, improper or inadequate maintenance or use Of non-recommended fuels and lubricating oils; accident-caused damage, and replacement of expendable Items made in connection with scheduled maintenance. **YANMAR** disclaims any responsibility for Incidental or consequential damages such as loss of time, inconvenience, loss of use of equipment/engine Or commercial loss.

[Owner's Warranty Responsibilities]

As the engine owner, you are responsible for the performance of the required maintenance listed in Your owner's manual. YANMAR recommends that you retain all documentation, including receipts, covering maintenance on your non-road compression-ignition engine, but **YAN-**

MAR cannot deny Warranty solely for the lack of receipts, or for your failure to ensure the performance of all scheduled maintenance.

YANMAR may deny your warranty coverage of your non-road compression-ignition engine if a part has Failed due to abuse, neglect, improper maintenance or unapproved modifications.

Your engine is designed to operate on diesel fuel only. Use of any other fuel may result in your engine no Longer operating in compliance with applicable emissions requirements.

You are responsible for initiating the warranty process. You must present your engine to a **YANMAR** Dealer As soon as a problem exists. The warranty repairs should be completed by the Dealer as expeditiously as Possible. If you have any questions regarding your warranty rights and responsibilities, or would like Infor-

mation on the nearest **YANMAR** Dealer or authorized service center, you should contact **YANMAR** America Corporation.

Website: (www.yanmar.com)

E-mail: CS.support@yanmar.com

Toll free telephone number:
1-800-872-2867, 1-855-416-7091



3. RK WARRANTY

WARRANTY

All products manufactured and supplied by RK have been designed and manufactured in compliance with all laws and regulations concerning agricultural equipment. If maintained and used in accordance with the inspections, regular maintenance and usage guidelines specified in the user's manual, this product is guaranteed to always safely maintain its optimum state and performance, as well as being guaranteed as follows.

1. Scope of Warranty

※ (Tractor Non-Rental & Non-Commercial)

If the agricultural equipment which you purchased is maintained and used normally in accordance with the inspections, regular maintenance and usage guidelines in the user's manual provided by our company, our company shall provide repairs and replacement at our expense for any parts which are revealed by technical analysis during the warranty period below to be defective due to a flaw in the materials or manufacturing.



WARRANTY

※ (Tractor Rental & Commercial)

If the agricultural equipment which you purchased is maintained and used normally in accordance with the inspections, regular maintenance and usage guidelines in the user's manual provided by our company, our company shall provide repairs and replacement at our expense for any parts which are revealed by technical analysis during the warranty period below to be defective due to a flaw in the materials or manufacturing.

2. Warranty Period and Relevant Parts

The warranty period is applied as of the date upon which the agricultural machine was provided to the end user. The warranty period is considered to have ended when either the usage period or usage time expires.

- ① 36 months or 2000 hours of use from the date of purchase for the engine (excluding fuel devices and electronic components) and power transmission devices.
Power transmission devices refer to the interrupter, transmission, brakes, differential and reduction gear. Engines which have been replaced for free are guaranteed for 12 months.
- ② 24 months or 1500 hours for parts other than those listed in Section ① (not including consumables.) Replaced parts are guaranteed for 3 months or less; they are seen as expiring at the end of the regular warranty period.



COVERAGE

This Limited warranty is limited to RK repairing or replacing, at RK's option, warranted parts by an authorized RK RK Tractor store at no charge for either the parts or services. Parts replaced under this Limited Warranty are only warranted for the balance of the warranty period.

1. RK shall have no obligation or liability under this warranty.

- (1) for normal maintenance or operation services for Products, including but not limited to, providing lubricants, fuel, tune-up inspection or adjustments.
- (2) for any consumable parts when such parts are replaced as a part of normal maintenance or operating services.
- (3) to any exclusions and limitations contained in the Limited Warranty.

2. Options, accessories, attachments installed by RK Tractor stores which are not manufactured by RK will not be warranted in any way by RK. For information about the warranty or to obtain warranty service on such parts, RK Tractor stores should contact the manufacturer directly



WARRANTY

3. The Limited Warranty is exclusive and in lieu of all other warranties, whether written, Oral, express or implied, including any warranty of merchantability or fitness for particular purpose.

The liability of RK under this warranty is expressly limited to the provisions in the Limited Warranty and in no event shall RK incur any liability (including liability for general, special, incidental or consequential damages, or economic or moral loss, arising out of any failure of the Products) which is not expressly assumed by RK under this warranty.

RK

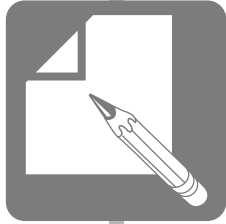

INDEX

1. INDEX.....10-2



INDEX

A

ABOUT THIS MANUAL	1-3
ADJUSTING THE BRAKES	5-20
ADJUSTING THE THROTTLE LEVER	5-21
ADJUSTING TOE-IN	5-22
ADJUSTMENT METHOD	5-21
ADJUSTMENT OF THE CHECK CHAIN	3-18
ADJUSTMENT OF THE LIFT ROD	3-18
ADJUSTMENT OF THE YOKE ROD ON THE LOWER LINK	3-18
AIR CLEANING SYSTEM	5-29
ALWAYS USE SAFETY LIGHTS AND DEVICES	2-5
ANTI FREEZE	5-19
APPENDIX	8-1
AVOID HIGH-PRESSURE FLUIDS	2-6

B

BATTERY CHARGING	4-6
BATTERY CHARGING	5-22
BATTERY DISCONNECT	2-8
BATTERY MAINTENANCE	5-22
BATTERY MAINTENANCE	5-22
BRAKE	5-5
BRAKE PEDAL	3-10

10 - 2

BRAKES	5-30
--------------	------

C

CHANGING ENGINE OIL	5-15
CHANGING OIL IN THE FRONT AXLE	5-16
CHANGING THE COOLANT	5-18
CHANGING THE OILS IN THE TRACTOR	5-14
CHANGING THE TRANSMISSION OIL	5-15
CHECK DURING DRIVING	4-6
CHECKING ENGINE COOLANT	5-2
CHECKING HOSES AND LINES	5-25
CHECKING THE WIRING HARNESS AND FUSES	5-25
CHECKS AND SERVICE	5-2
CLEAN AND CHANGE FILTER	5-17
CLEANING OIL WATER SEPARATOR	5-14
CLEANING THE AIR CLEANER DUST VALVE	5-24
CLEANING THE FUEL FILTER	5-13
CLEANING/CHANGING THE ELEMENT	5-24
COOLING SYSTEM	5-31
CRUISE CONTROL LEVER	3-5

D

DAILY OPERATION LOG	8-6
DAMAGE OF THE ROPS	1-8



INDEX



DECALS ON THE CHASSIS.....	2-25	ENGINE OIL FILTER CARTRIDGE.....	5-18
DECALS ON THE CHASSIS.....	2-26	ENGINE SYSTEM.....	5-30
DECALS ON THE DASH COVER.....	2-24		
DECALS ON THE SEAT.....	2-27	F	
DESCRIPTION	1-5	FALLING OBJECT PROTECTIVE STRUCTURE (FOPS) ...	2-13
DESCRIPTION OF TRACTOR CONTROLS.....	3-1	FAN BELT ADJUSTMENT.....	5-23
DETACHING THE LOADER.....	5-6	FAULT TRACING.....	7-2
DIFF-LOCK PEDAL.....	3-11	FILLING DIAGRAM & CAPACITY TABLE	5-10
DO NOT WELD, DRILL OR STRAIGHTEN THE ROPS	1-8	FOR DAILY OR SHORT TERM STORAGE	5-27
DO'S AND DON'T'S	2-22	FOR SLIDING SEAT	1-9
DO'S-FOR BETTER PERFORMANCE.....	2-22	FRONT AXLE PIVOT PIN	5-20
DON'TS-FOR SAFE OPERATION	2-23	FRONT WHEEL DRIVE LEVER.....	3-11
DRAWING FOR FIXING POSITION OF THE FUSE.....	8-2	FUEL	5-4
DRIVER'S SEAT.....	3-12	FUEL	5-13
DRIVING DOWNHILL.....	4-5	FUEL GAUGE	3-4
		FUEL GAUGE	4-6
E		FUEL SAVING TIPS	5-29
ELECTRICAL	5-5	FUEL SYSTEM.....	5-30
EMERGENCY EXITS.....	2-9		
EMISSION SYSTEM WARRANTY.....	9-5	G	
ENGINE.....	5-29	GAP ADJUSTMENT	5-20
ENGINE COOLING WATER.....	4-7	GENERAL INFORMATION.....	1-1
ENGINE OIL	5-3	GENERAL INFORMATION.....	5-2
ENGINE OIL FILTER.....	5-17	GENERAL SAFETY INFORMATION.....	2-24

10-3



INDEX

G

GREASING THE TRACTOR 5-20

H

HANDLE FUEL SAFELY AVOID FIRES 2-5

HAZARD WARNING SIGNAL SWITCH 3-5

HEAD LAMP, TURN SIGNAL SWITCH AND HORN 3-3

HOURLY METER 3-3

HOW TO ADJUST THE SEAT 1-9

HYDRAULIC POSITION CONTROL LEVER 3-15

I

INDEX 10-1

INSTALLING LOADER 5-5

INSTRUMENT AND SWITCHES 3-2

INTRODUCTION & DESCRIPTION 1-4

K

KEEP RIDERS OFF TRACTOR 2-4

L

LONG-TERM STORAGE 5-28

LOWERING SPEED CONTROL KNOB FOR THE 3
POINT HITCH 3-16

10 - 4

LUBRICANTS 5-11

LUBRICATION & MAINTENANCE 5-1

M

MAIN FUSES 5-26

MAIN SWITCH (KEY SWITCH) 3-3

MAINTENANCE AND ADJUSTMENT SCHEDULE 5-7

MID PTO 3-14

MOUNTING AND DEMOUNTING IMPLEMENTS 2-17

MOUNTING IMPLEMENT 3-19

NORMAL BRAKING AND PARKING 4-4

O

OIL PRESSURE LIGHT 4-6

OPENING METHOD OF EACH COVER 5-12

OPENING METHOD OF FAN COVER 5-12

OPENING THE SIDE COVER 5-12

OPERATING THE 3 POINT LINKAGE (TPL) 3-17

OPERATING THE HYDRAULICS 3-15

OPERATION 4-1

OPERATION OF THE DIFF LOCK 4-5

OPERATION THE CONTROLS 3-8

OPERATOR PROTECTIVE STRUCTURE (OPS) 2-13

OWNER ASSISTANCE 1-6



P

PANEL INSTRUMENT LAMP 3-6

PARK TRACTOR SAFELY 2-4

PARKING BRAKE LEVER 3-10

PART REPLACEMENT RECORD 8-7

PARTS 1-2

PERIODICAL CHECK AND SERVICE TABLE 5-7

PRACTICE SAFE MAINTENANCE 2-6

PRECAUTION TO AVOID TIPPING 2-4

PRE-START CHECKS 5-2

PREVENT ACID BURNS 2-7

PREVENT BATTERY EXPLOSIONS 2-7

PROTECTION CHILDREN 2-3

PTO 3-13

PTO ON/OFF SWITCH 3-7

R

READ SAFETY INSTRUCTION 2-2

REAR PTO 3-13

RECOGNIZE SAFETY INFORMATION 2-2

RECOMMENDED TRANSMISSION OIL 5-11

REPLACING FUSES 5-26

RE-USE AFTER LONG TERM STORAGE 5-28

RK WARRANTY 9-9

ROLL OVER PROTECTIVE STRUCTURES (ROPS) 1-7

ROPS (ROLL OVER PROTECTIVE STRUCTURES) 1-7

S

SAFE OPERATION OF YOUR TRACTOR 2-15

SAFETY INSTRUCTIONS 2-2

SAFETY PRECAUTIONS 2-1

SAFETY PRECAUTIONS WHEN USING THE LOADER 2-10

SAFETY SIGNS 2-24

SAFETY STARTER SWITCH 2-9

SAFETY TIPS DURING MAINTENANCE 2-16

SERVICE 1-2

SERVICE PRIOR TO DAILY AND SHORT TERMS STORAGE 5-27

SERVICE RECORD 8-5

SERVICE THE AIR CLEANER 5-24

SERVICE TRACTOR SAFELY 2-8

SIGNAL WORDS 2-2

SPECIFICATION 6-1

SPECIFICATIONS 6-2

SPEED CHART (ENGINE RATED SPEED) 6-6

SPEED CONTROL PEDAL 3-9

STARTING THE ENGINE 4-2

STAY CLEAR OF ROTATING SHAFTS 2-5



INDEX

S

STEERING	5-5
STOPPING THE ENGINE	4-3
STORAGE	5-27
STORING ENGINE IN OPERABLE CONDITION FOR 3 MONTHS OR MORE	4-4
SUB GEAR LEVER (RANGE SHIFT LEVER).....	3-10

T

TACHOMETER.....	3-4
THE FOLLOWING PRECAUTIONS ARE SUGGESTED TO HELP PREVENT ACCIDENTS	2-18
THROTTLE LEVER (HAND THROTTLE)	3-9
TIRE PRESSURE.....	5-5
TOWING SAFELY	2-12
TRACTOR AN INTRODUCTION	1-4
TRACTOR HISTORY CARD	8-4
TRACTOR IDENTIFICATION	1-2
TRACTOR RUNAWAY	2-9
TRANSMISSION OIL	5-4
TROUBLESHOOTING	7-1
TROUBLESHOOTING	7-2

U

UNIVERSAL SYMBOLS.....	2-28
USE OF HAZARDOUS SUBSTANCES	2-14
USE OF ROPS AND SEAT BELT	2-3
USE OF THE TRACTOR WITH THE ROPS LOWERED CAN CAUSE FATAL INJURIES	1-7

W

WARMING UP	4-3
WARMING UP IN COLD WEATHER	4-3
WARRANTY	9-1
WARRANTY OF THE PRODUCT	1-2
WATER TEMPERATURE WARNING LAMP	3-4
WIRING DIAGRAM OF THE ELECTRIC INSTRUMENT	8-3
WORK IN VENTILATED AREA	2-8

Y

YANMAR WARRANTIES.....	9-2
------------------------	-----